

<b>NIT NO</b>	<b>BHO202004031</b>
<b>DATE</b>	29/04/2020



**SBI INFRA MANAGEMENT SOLUTIONS PVT. LTD., (SBIIMS),**  
(WHOLLY OWNED SUBSIDIARY OF SBI)

BHOPAL CIRCLE OFFICE

INVITES e-TENDERS ON BEHALF OF SBI

**THROUGH E-TENDERING PROCESS**

FOR

## **ELECTRICAL & AC WORKS OF DSH, BETUL**

Contractors who are on the panel of SBI, A. O. Bhopal in the appropriate Electrical & AC work category and NIT is sent to them are only eligible.

Note: Firm should possess valid digital signature for this e-tender.

Last date for submission of e-Tender: 3.00 P.M. (IST) on 08/05/2020

Opening of e Tenders: 3.30 P.M. (IST) on 08/05/2020

**The Vice President & Circle Head,  
SBI Infra Management Solutions Pvt. Ltd.  
Bhopal Circle Office  
Mezzanine Floor, SBI Bhopal LHO Building,  
Hoshangabad Road  
Bhopal- 462 011  
Ph: 0755-2572553**

**NOTICE INVITING TENDER (NIT)**

**NAME OF WORK: e-TENDER Notice for Electrical & AC Works of DSH, BETUL.** Online e-Tenders are invited for the above mentioned work from the empanelled contractors of SBI of the appropriate Electrical & AC work category and NIT is sent to them by us.

1	Name of the work	<b>E-Tender Notice for Electrical &amp; AC Works of DSH , BETUL BHOPAL</b>
2	Cost of Tender Documents-cum-Processing Fee	Rs.3,000/- to be credited on through State Bank Collect (SB Collect an efficient MIS report generation tool). The steps involved in making the payment is provided at Annexure-A. The receipt generated with reference No. will be submitted along with Technical bid. <b>GST number of contractor to be mentioned</b>
3	Date and Time where tender forms are available (From _____ to _____)	FROM 30.04.2020 to 08/05/2020 at <a href="https://etender.sbi/">https://etender.sbi/</a>
4	Time and last date of submission of online eTender	Up to 3.00PM on 08/05/2020
5	Place, Time & Address for submission of e tender/contact person /telephone no/email address.	Up to 3.00 p.m. on 08/05/2020 <b>A) Tender documents at <a href="https://etender.sbi/">https://etender.sbi/</a></b> <b>B) Documents-cum-Processing Fee and EMD at the Address:</b> SBI Infra Management Solutions Pvt. Ltd. Bhopal Circle Office Mezzanine Floor, SBI Bhopal LHO Building, BETUL Road, Bhopal- 462 011 Ph: 0755-2572553
6	Date, Time and Place of opening of e-Tenders	e- mail id : headbho.sbiims@sbi.co.in On 08/05/2020 at 4:30PM SBI Infra Management Solutions Pvt. Ltd. Bhopal Circle Office Mezzanine Floor, SBI Bhopal LHO Building, BETUL Road Bhopal – 462 011 Ph: 0755 2572553
7	Quantum of Earnest Money Deposit (EMD) ` _____ drawn in favour of _____ Payable at _____	Rs.6,000/- (DD-Drawn in favour of Vice President & Circle Head, SBIIMS, Bhopal payable at Bhopal)
8	Quantum of Security Deposit _____ (percentage) drawn in favour of _____ Payable at _____. Amount of bank guarantee.	1. Initial Security Deposit (ISD) – 2% of the Tender value including EMD 2. Retention Money- Deductable in running bills@ 10% of the value of work and Total deductible is 5% of value of work including EMD, ISD.
9	Terms of payment of Bills, if any (specify the minimum value of work for payment of running account bills)	1. <b>Rs.3,00,000.00</b> 2. <b>No Advance will be paid</b>
10	(Penalty clause) Liquidated Damages	@ 0.5% of the value of work per week of delay subject to a maximum penalty of 5% of the value of work would be strictly imposed.
11	Stipulated time for completion of the work/supply.	21 Days (from date of removal of lockdown)
12	Validity period of the tender.	90 days from last date for receipt of tender

13	Eligible Taxes	<p><b>A )</b> Income Tax will be deducted at source as per Govt. Guidelines.</p> <p><b>B) Payment of GST will be made as applicable. The contractor should comply with the following;</b></p> <p>Contractor should have GST Registration Number.</p> <p>Invoice should specifically/separately disclose the amount of GST levied at applicable rate as per GST provisions/Rules.</p> <p>In case of Correction in the bills after scrutiny, contractor should submit fresh bills for payment.</p> <p>Contractor should timely file his GST return in accordance with GST provisions to enable the bank to claim the credit of GST paid to the contractor.</p> <p>The GST Number of State Bank Of India are For Madhya Pradesh -23AAACS8577K1ZX</p>
14	<b>Electronic Payment</b>	Electronic payment shall be preferred. All the contractor must furnish details such as 1) Name of the their bank 2) Name of their branch 3) Account number 4) Name of the account holder as in the bank account 5) IFSC No of the branch 6) PAN number.
15	Agency for arranging e-tender/online bidding, contact numbers	<p>e-Procurement Technologies Limited, Ahmedabad. Tel.:- 079 – 681368 40/ 31 / 35 / 63 / 29 / 57 / 53 / 43 / 52 / 20 / 59 / 22</p> <p>Mobile: +91 9904407997 / 9081000427</p> <p>Email: <a href="mailto:sujith@auctiontiger.net">sujith@auctiontiger.net</a>, <a href="mailto:sujith@eptl.in">sujith@eptl.in</a>, <a href="mailto:jaymeet.rathod@auctiontiger.net">jaymeet.rathod@auctiontiger.net</a>, <a href="mailto:jaymeet.rathod@eptl.in">jaymeet.rathod@eptl.in</a>, <a href="mailto:mehnaz@eptl.in">mehnaz@eptl.in</a>, <a href="mailto:vinyayak.k@eptl.in">vinyayak.k@eptl.in</a>, <a href="mailto:pratik.parekh@eptl.in">pratik.parekh@eptl.in</a>, <a href="mailto:anshul.juneja@eptl.in">anshul.juneja@eptl.in</a>, <a href="mailto:devang@eptl.in">devang@eptl.in</a>, <a href="mailto:dharam@eptl.in">dharam@eptl.in</a>, <a href="mailto:aman.v@procuretiger.com">aman.v@procuretiger.com</a></p>
16	For further clarifications, if any	<p>All technical matters contact</p> <p>Sri. N K KAWDE SBIIMS BHOPAL- 0755 2572553</p>
17	<b>Any additional Information</b>	The quoted rate should be inclusive of materials, labour, wages, fixtures, transportation, installation, all taxes (but excluding GST), wastages, Octroi, machinery, temporary works such as scaffolding, cleaning, overheads, profit, statutory expenses, incidental charges and all related expenses to complete the work

**The D.D./ B.C. of E.M.D. shall be submitted/received (otherwise the tender shall be summarily rejected) at the above mentioned address on or before the opening date/time of Tender.**

The contractor has to provide their E-mail id, contact nos. and postal address in the bid documents. Henceforth, all official communication from Bank/SBIIMS shall be through E-mail and SMS also.

The SBIIMS reserves the right to cancel or postpone or modify the tenders at any stage without assigning any reason.

**The Vice president & Circle Head**

**INSTRUCTIONS TO TENDERERS**

Online, e tenders are invited for ELECTRICAL & AC OF DSH BETUL, from the Contractors of eligible Category, Empanelled in the State Bank of India, A O, Bhopal.

1. Submission of BIDs/Tender Documents: Tenders should be submitted online in the website <https://etender.sbi/>. In addition, scanned copy of the declaration given in the last page signed with seal and scanned proof of empanelment and its validity should be submitted online with our service provider on the website at: <https://etender.sbi/> The tender document is not required to be sent to us in hard copy. The Tender documents with acceptance of all terms and conditions strictly as described in this tender document will be submitted online through M/s e-Procurement Technologies Ltd., Ahmadabad, the out sourcing agency approved by the Bank for e-tendering on the website <https://etender.sbi/>
2. Contractors should submit/sent EMD physically on or before 3.00 p.m on last date at the office of the Vice President, SBI Infra Management Solutions Pvt. Ltd., Bhopal Circle Office, Mezzanine Floor, SBI Bhopal LHO Building, BETUL Road, Bhopal. The tender will be rejected if the tenderer fails to submit the above documents such as soft copy of complete tender documents, scanned copies of proof of empanelment, declaration, EMD and application fee.
3. Contract documents consist of detailed plans, technical specification, schedule of quantities of the various classes of work to be done, and the set of 'conditions of contract' to be compiled with by the person whose tender may be accepted. The documents are available in the website <https://etender.sbi/>
4. The successful tenderer will have to pay an amount of Initial Security Deposit, which shall be 2% of the accepted value of the tender including the EMD, by means of D.D. The Initial security deposit is to be paid by the Contractor to Bank within 15 days of intimation to him of the acceptance of the tender. No interest is allowed on the above said security deposit(EMD, ISD)
5. Retention Money: From each running bill, an amount at the rate of 10% of the gross value of the running bill shall be recovered as retention money, till the total retention amount including the EMD and ISD amounts already with the Bank become 5% of the value of the contract amount. This amount is called as Total Security Deposit, which consists of three components
  - a) EMD - Earnest Money Deposit.
  - b) ISD - Initial Security Deposits.
  - c) RM - Retention Money.

The total security deposit will be kept with the Bank. Out of Total Security Deposit 50% of the total security deposit amount shall be refunded without interest to the contractor on issuance of virtual completion certificate by the Architect/Bank/SBIIMS and the Contractor's removal of his materials, equipment, labour force, temporary sheds, stores, site office etc. and on receipt of physical possession of the site by the Bank. The remaining 50% of the total security deposit may be refunded 15 days after the end of defects liability period(6 months), provided he has satisfactorily carried out all the works and attended to rectification of all defects in accordance with the conditions of the contract. In case of failure on the part to do so, the cost of rectifying the defects through any other agency shall be deducted from the amount of security deposit due to the contractor.

Completion of work: :i) The work shall be considered as complete only when the certificate of virtual completion is issued by the architects/Bank/SBIIMS.ii) The 'defects liability period' as prescribed in the contract shall commence only from date of such virtual completion.iii) Any defect that may appear within the defects liability period shall be rectified by the contractor within reasonable time on receipt of necessary instructions from Bank/SBIIMS to that effect.

The acceptance of a tender will rest with the Competent Authority, who does not bind himself to accept the lowest tender and reserves to himself the authority to reject any or all of the tenders received, without assigning any reasons. All tenders in which any of the prescribed conditions are not fulfilled, or are incomplete in any respect are liable to be rejected.

6. All compensation or other sums of money payable by the Contractor to Clients under the terms of this contract may be deducted from the security deposit, or from any sum that may be or may become due to the Contractor on any account whatsoever and in the event of the Security Deposit being reduced by reasons of any such deductions, the Contractor shall within 7 days of being asked to do make good in by DD any sum which have been deducted from his security deposit.
7. Tender containing any condition leading to unknown / indefinite liability, are liable to be summarily rejected.
8. Canvassing in connection with tenders is strictly prohibited and the tenders submitted by the contractors who resort to canvassing will be liable to rejection.
9. The tenderer should quote their (own) rates for undertaking the work.
10. GST as applicable will be paid at the time of payment of bill.
11. All taxes other than GST, other statutory obligation in respect of this contract, as applicable, shall be payable by contractor including transportation and TA / DA of the workers at site and the Bank/SBIIMS will not entertain any claim whatsoever in this respect
12. I.T. will be recovered as per Government Rules
13. Time is the essence of the contract. The work should be completed within the time mentioned in NIT from the date of the work order issued to the contractor to commence the work. The successful Contractor will have to give CPM/PERT chart of various activities of works to be done so that the work gets completed within the stipulated time. The chart shall be submitted within 7 days from the date of acceptance of the tender.
14. Tenders for works shall remain open for acceptance for a period of 90 days from the last date of tenders. If the tenderer withdraws his tender before the expiry of the said period or makes any modifications in terms and condition of the tender which are not acceptable to the Bank, then the Bank/SBIIMS without prejudice to any other right or remedy is at liberty to forfeit the earnest money.
15. The successful tenderer, after the work is awarded, he will have to enter into an agreement with the competent authority of the bank.
16. The tenderer, must co-ordinate with the other agencies such as (I) Electrical (II) Air – Conditioning etc.
17. The tenderer should visit the site to ascertain the working conditions and local authority regulations / restrictions if any and other information required for the proper execution of the work. The work should be carried out at any floor.
18. The work is to be carried out on different floors level depending upon the nature of work. Please note that materials and machines are required to be carried on head load and the same must be accounted in the costing. Please note that no separate cost shall be allowed for carting and shifting of materials.
19. The quantities of various items given in the schedule of quantities are approximate. The quantities of work may vary at time of allotment / execution of work. Bank/SBIIMS reserves the right to omit / delete any item(s) of work from the schedule at the time of allotment / before. Contractor will be paid for the actual work done at the site duly verified by the concerned official of the Bank / SBIIMS.

20. The unit price shall be deemed to be fixed price. In case of extra items, a record of labour charges paid shall be maintained and shall be presented regularly to the Employer's for checking. The settlement will be made based on figures arrived at jointly and taking unit price given in the contract assigned to the successful Tenderer. In case of extra items where similar or comparable items are quoted in the tender, extra rates shall be based on tender rates.
21. If the rate quoted by the contractor for any item / items are not workable or abnormally lower than the market rate, the Bank/SBIIMS may demand Bank guarantee from the contractor for satisfactory completion of these work. The bank guarantee amount will be not less than 50% of the estimated amount of the items for which the rates are not workable or abnormally low. This bank guarantee will be released after completion of these works (unworkable and abnormally low rated items) to the satisfaction of the Bank/SBIIMS.
22. The contractor shall submit the bar chart/ CPM/ PERT as well as shall submit the insurance cover for the work in the form of CAR policy and Third Party Insurance within seven (7) days from the acceptance of work order.
23. The work has to be started within 7 (Seven) Days from the date of receipt of work order/ mark out at site; whichever is later. In case of work not being started within this stipulated period, the Bank/SBIIMS reserves the right to cancel the work order duly forfeiting the Earnest money deposit
24. No employee of the Bank/SBIIMS is allowed to work as a contractor for a period of 2 years of his/her retirement from Bank/SBIIMS Services without previous permission of the Bank/SBIIMS. This contract is liable to be cancelled, if either the contractor or any of his employees is any time to be such a person who had not obtained the permission of Bank/SBIIMS as aforesaid before submission of the tender or engagement in the contractor's service.
25. Contractor should get approval of the samples of materials in advance with Bank/SBIIMS's Engineer before use of the same in the work'
26. Bank/SBIIMS has the right to offer the contractor to modify the old material wherever/ whenever necessary instead of new supplies
27. The quoted rate should be inclusive of materials, labour, wages, fixtures, transportation, installation, all taxes(excluding GST), wastages, Octroi, machinery, temporary works such as scaffolding, cleaning, overheads, profit, statutory expenses, incidental charges and all related expenses to complete the work
28. The tenders shall summarily rejected, if any one of the above said requirements has not been complied with.
29. The Bank/SBIIMS will not be bound to accept the lowest tender and reserves the right to accept or reject any or all the tenders without assigning any reason whatsoever
30. The contractor should fulfill the labour regulation guidelines stipulated by the governments
31. No advance payment in any form will be granted for the works proposed
32. Period of taking up the final bill will be one month from/ after satisfactory virtual completion or the date of submission of the final bill whichever is later.
33. If in the opinion of the SBIIMS the rates quoted by any Contractor are found unworkable keeping in view the specifications proposed and workmanship expected the SBIIMS may choose to reject such tenders within its sole discretion without notice to the Contractors and no correspondence will be entertained by the SBIIMS in this regard.
34. In case you are not interested to quote your rates for subject work please return all tender documents.
35. All safety code, CPWD specifications, respective Indian Standard code of practice and direction of Engineer-in-charge will be meticulously followed while executing the work.

36. The Contractor has to obtain approval of materials/samples from the Engineer-in-charge prior to its procurement and use in execution of work.
37. The tools, plants & machineries etc. required for execution of work shall be used as per direction of the Engineer-in-charge to achieve the desired quality of work. For concealed items which can not be checked / verified after execution, the Contractor will inform the SBIIMS in advance with sufficient time to verify and inspect such items by the Engineer to facilitate the measurements and ensure quality of work. The materials shall be first approved by the Engineer-in-charge before incorporating in construction. If any brand/make/specification of the item is missing or not specified in the tender the necessary approval/clarification may be obtained from the Engineer .The Contractor whose tender is accepted shall further deposit Initial Security Deposit (ISD) of 1% of the accepted tender amount in addition to the already deposited EMD to constitute 2% of the accepted tender amount. The Contractor will enter into an agreement with the Bank and SBIIMS for the proposed work. The proforma of the agreement is enclosed.
38. For clarification, if any, the drawing, /details referred to in the enclosed schedule of price bid can be discussed with SBIIMS Engineer, Circle / Administrative Office Bhopal during office hours before the date of submission of tender. The Employer reserves to itself the right of altering the drawings/specifications nature of the work by adding to or omitting any items of work or division of work amongst agencies having portions of the same carried out without prejudice to this contract.
39. The Contractor will submit Bank's guarantee against the low rated items and the same may be released only after the successful completion of the work. In case the work is found of sub standard nature the Bank Guarantee may be revoked.
40. The electrical work, if required at site, shall be carried out through 'A' class licence holder electrical contractor who are empanelled with SBIIMS . However all responsibilities will be of civil Electrical & AC work contractor for executed electrical work.

I/We hereby declare that I/We have read the above terms and conditions /instructions Carefully and fully understood and will abide by the same.

**Signature of the tenderer with seal & Date:**

**Vice President**

READ, UNDERSTOOD AND ACCEPTED

**SIGNATURE OF THE CONTRACTOR WITH SEAL**

**Date**

FORM OF SUBMISSION OF TENDER  
(To be filled by the tenderer)

**The Vice president,  
SBI Infra Management Solutions Pvt. Ltd.  
Bhopal Circle Office  
Mezzanine Floor, SBI Bhopal LHO  
Building, Hoshangabad Road  
Bhopal – 462 011**

Dear Sir/s,

Ref: TENDER FOR ELECTRICAL & AC WORKS OF DSH BETUL

I/We hereby declare that I/ We have carefully gone through the conditions laid down in the Notice Inviting Tender, General notes, General Conditions of Contract, Special conditions, Schedule of approximate quantities and rates, Form of Agreement, General Specification, Approved manufacturers/ natural source of materials Technical Specifications of schedule of quantities, and clearly understood all the same and on the basis of the same I/ We have quoted our rates in the Schedule of Quantities (i.e. BOQ) attached with the tender documents.

I / We do here by undertaken to execute and complete the whole or part of the work (as desired by you) at the respective rates quoted.

I/ We are depositing a sum of Rs.\_\_\_\_\_.00 (Rupees \_\_\_\_\_ ONLY ) as earnest money deposit by way of demand draft drawn in favor of Regional Manager, RBO, State Bank of India along with this tender for due execution of the work at my/ our tendered rates.

In the event of this Tender being accepted I/ We agree to enter into the agreement and submit the declaration on requisite non-judicial stamp papers as and when required and execute the contract according to your form of Agreement etc., in default whereof, I/ We do hereby bind my-self / ourselves to forfeit the aforesaid deposit.

In the event of this Tender being accepted I/ We agree to obtain the labor license and the CAR and Third party insurance policy and deposit the balance E.M.D. amount and adhere/comply to all other instructions as given in TENDER DOCUMENT.

I / We further agree to complete the work included in the said schedule of quantities within the time mentioned in the NIT from the date of the work order issued to commence the same.

Date of commencement shall be either one week from the date of work order issued to the contractor or the date on which mark out of work at site has been given to contractor; whichever is later.

I / We agree not to employ sub-contractors other than those that may be approved by Employer.

I / We agree to pay all taxes(except GST), insurance charges as prevailing from time to time, on such items for whom same is to be levied by/ for the government, and the rates quoted by me / us are inclusive of all the same.

Yours Faithfully,

Signature of Witness:

Contractor's Signature\_\_\_\_\_

1.

Name: \_\_\_\_\_

2.

Address: \_\_\_\_\_

3.



## **GENERAL NOTES**

### **1. PROCEDURE OF FILLING AND SUBMISSION OF TENDER**

- i) Submission of BIDs/Tender Documents: Tenders should be submitted online in the website <https://etender.sbi/> In addition, scanned copy of the declaration given in last page to be signed with seal and scanned proof of empanelment and its validity should be submitted online with our service provider on the website at: <https://etender.sbi/> The tender document is not required to be sent to us in hard copy. The Tender documents with acceptance of all terms and conditions strictly as described in this tender document will be submitted online through M/s e-Procurement Technologies Ltd., Ahmadabad, the out sourcing agency approved by the Bank for e-tendering.
- ii) In the event of the tender being submitted by a firm, it must be signed by a member or members of the firm having legal authority to do so, and if called for, the legal documents in support thereof must be produced for inspection and the same in the case of the firm carried out by one member of a joint family. It must disclose that the firm is duly registered under the India Partnership Act. Any tender signed by a member not holding a power of attorney shall be treated as informal.

Tenderer shall note that their tenders shall remain open for acceptance for a minimum period of three months from the last date of receipt of tenders. The tenders must be unconditional. Conditional tenders may be summarily rejected.

### **2. RATES TO INCLUDE:**

While quoting their rates the tenderer should include the following if otherwise not stated herein before.

- a) Materials, labour, wastages, overhead, transport, sample testing charges etc all for completing work.
- b) Necessary cost of taking samples of materials supplied by them for work including plywood, wood/tiles etc., testing of the same at Govt.'s / approved laboratory including transportation, cost of the samples, as and when required.
- c) Submission of test reports of other materials as may be specified by Bank/SBIIMS's Engineer.

### **3. STORAGE OF MATERIALS:**

The contractor shall not store their materials and debris within the premises other than the work site handed over to him.

### **5. LABOUR HUTMENT:**

Shelter or stay and other amenities for the labors have to be arranged by the contractor at his own expense and responsibility.

### **6. IDLE LABOUR:**

In case the work is held up for any site conditions not attributable to the contractors or for any decisions instructions / want of details from Employer or for any of the conditions, the contractor shall be allowed reasonable extension of time by the employer but any claim for idle labour shall not be entertained by the employer. Contractor's quoted rates should include for all such contingencies.

7. The contractor shall engage one competent person at site who shall take the instructions from the Employer. The work should not suffer due to lack of supervision, manpower and materials.

8. The Contractor is required to co-ordinate his works along with other agencies working at site. He has to reimburse any of the damage made by him or any of his representatives for any of the other agency or owner at site.

9. Making of any cut-out / opening for electrical wiring / fitting in any of false ceiling, partition, Paneling, masonry work etc., and providing panels of the same finish in partitions, paneling shall not be paid extra.

10. The contractor is required to fabricate a sample where required, or any item so installed for approval. Any changes made by the Architect/Employer, in the sample to the specifications as mentioned in the tender, shall not be deducted or paid extra. The bulk production of the furniture can only be taken up after the final approval of the sample of the item.

11. The partitions shall be so fixed that all joinery work is in plumb and true in line. The partition frame shall be firmly fixed to the floor and ceiling by using suitable wall plugs and screws.

12. The contractor shall check all dimensions before fabricating and fixing the partitions or any other items in position at site.

13. All measurements given in the schedule hereunder are for the purpose of tender only. Payment will be made on actual measurement of the work done.

14. All measurements shall be as per relevant I.S. standards.

## **SPECIAL CONDITIONS OF CONTRACT**

### **1. DRAWINGS AND SPECIFICATIONS**

The works shall be carried out to the entire satisfaction of the EMPLOYER and the Architect, in accordance with the signed drawings and specifications and such further drawings and details as may be provided by the Architect/Employer, and in accordance with such written instructions, directions and explanations as may from time to time be given by the Employer/Architect, whose decision as to the sufficiency and quality of the work and materials shall be final and binding upon all parties. If the work shown on any such further drawings or work that may be necessary to comply with any such instructions directions or explanations, be in the opinion of the contractor extraction that comprised in or reasonably to be inferred from the contract he shall before proceedings with such work, give notice in writing to this effect to employer/Architect, and in the event of the employer/Architects agree to the same in writing the contractor shall be entitled to an allowance in respect of such extra work as on authorized extra. If the Architect and the contractor fail to agree as to whether or to there is an extra, then, if the Architect decided that the contractor is to carry out the said work, the contractor shall do so, and the question whether or not there is any extra, and it so the amount thereof, shall failing agreement, be settled by Arbitration as hereinafter provided, but such references shall in no way delay the fulfillment of this contract.

No drawings shall be taken as in itself on order for variation unless, in addition to the employer/Architect's signature, it bears express words stating that is intended to be such an order or bears a remark '**VALID FOR EXECUTION**'. No claim for payment for extra work shall be allowed unless the said work shall have been executed under the provisions of clause 6 (Authorities notices, patent right and royalties) or by the Authorities of directions in drawing of the Architect as herein mentioned.

One complete set of the signed drawings and specification and scheduled of quantities shall be furnished by the Architect to the Contractor. The Architect shall furnish within such time, as he may consider reasonable, one copy of any additional drawing, which is his opinion, may be necessary for the execution of any part of work. Such copies shall be kept at the works, and the architect or his representatives shall, at all reasonable time have access to the same and shall be return to the Architect by the contractor before the issue of the Final certificate. The contract shall remain in the custody of the Architect, and shall be produced by him at his office as and when required by the Employer or by the contractor.

### **2. INSPECTION OF DRAWINGS**

Before filling in the tender, the contractor will have to check up all drawings/specification and schedule of quantities, and will have to get an immediate clarification from the employer/Architect on any point that he feels is vague or uncertain. No claim of damages or compensation will be entertained on this account.

### **3. EXECUTION OF WORK (PRICES TO INCLUDE)**

The whole of the work is described in the contract a (including the schedule of Quantities, the specifications and all drawing pertaining there to) and as advised by Employer / Architect from time to time is to be carried out and completed in all its parts to the entire satisfaction of the Employer /Architect. Any minor details of the work which may not have been definitely referred to in this contract, but which are usual in practice and essential to the work, are deemed to be include in this contract. Rates quoted in the Schedule shall be inclusive of all frights, Royalties, duties, etc., as well as transportation, so as to execute the contractor as per the rules and regulations of Local Bodies, State Government and Government of India.

The rates quoted in the tender should include all charges for:

- a) Labor, maintenance fixing, carrying, cleaning, making good, hauling, watering etc
- b) Plant, machinery, scaffolding, framework, English ladders, ropes, nails, spikes, tools, materials and workmanship protection from weather, shuttering, temporary supports, platform and maintenance of the same.
- c) Covering for the walling and other works during inclement weather or striking or whenever directed as necessary.

a) The rates quoted by contractor shall include removal of all the existing furniture and other material & dispose them off where ever required including the furniture and material for which the contract has given the pay back offer.

#### **4. SITE SUPERVISION**

The contractor shall appoint at his own cost competent and adequate number of qualified Engineers at site, for (1) joint measurements and preparations of bills, (2) for testing materials at site and outside laboratory, (3) for other general supervision. Their appointment shall be approved by the Employer / Architect. The site Engineers shall not be removed from the site without the written consent of the Employer / Architect.

#### **5. DIMENSIONS**

Figures, dimensions, are in all case to be accepted preferences to scaled sizes. Large-scale details take precedence over small scale drawings. In case of discrepancy, the contractor is to ask for a clarification before proceeding with the work. Accordingly if any work is executed without prior clarification it is liable to be rejected and shall not be paid for.

#### **6. PROGRAMME OF WORKS**

Contractor shall have to prepare and submit the CPM/PERT charges for employer approval immediately after issue of the work order and display the approved charts in the site office. He shall also make bar charts indicating individual items and during the progress of work he shall update the bar charts showing the proportionate progress of work every week.

He shall strictly adhere to the program of works as per CPM/PERT charts showing the proportionate progress of work.

#### **7. PROCUREMENT OF MATERIALS**

Contractor shall procure all the materials for the work from the open market. Time is the essence of the contract. Acceptance of the completion date by the contractor shall mean that he has taken into consideration the availability of all material of approved make and quality in sufficient quantities at site to enable him to complete the entire work in the stipulated period. Contractor will get sample of all materials approved by the Employer before placing order / purchase / procurement. They shall conform to I.S. codes and or tender specification as applicable.

For all materials the contractor shall quote for the best quality of the materials of best make / source or supply and it will be got approved by Employer before procurement. In case sufficient quantities of approved quality materials from approved source are not available in time, contractor may have to procure the same from neighboring area with longer leads as required and directed at no extra cost. The material will be, however as per relevant I.S code as and wherever applicable.

#### **8. UNFIXED MATERIALS**

When any materials intended for the works shall have been placed at site by the Contract, such material shall not be removed there from (except for the purposes of being used on the works) without the written authority of the Employer / Architect and when the contractor shall have received payment in respect of any certificate in which the architect shall have stated that he has taken in to account to value of such unfixed materials on the works such material shall become the property of the Employer and the contractor shall be liable for any loss or damage to any such materials.

#### **9. CUSTODY AND SECURITY OF MATERIALS**

The contractors shall be responsible for the custody and security of all materials and equipment at site and he will provide full time watchman / watchmen to lock after his materials, stores equipments etc.

## **10. RATES**

Rates quoted by the contractor shall hold good for all the work carried out to any height and depth as shown in detailed drawings and as required and directed by the Architect.

Rates quoted by the contractor shall also hold good for any small work at any place at site.

## **11. PRICES FOR EXTRAS ETC., ASCERTAINMENT**

The rates of extra items will be ascertained as below

- a) The rates will be derived from the rates of items already quoted in the original tender for the extra work.
- b) Where extra work cannot be properly measured or valued, the contractor shall be allowed any work prices at the net rates stated in the tender or the priced schedule of quantities, or if not so stated, then in accordance with the local day work, rates and wages for the district, provided that in either case vouchers specifying the daily time (and if required by the Architect, the workmen's name) and materials employed at or before the end of the week following that in which the work has been executed.
- c) The measurements and valuations in respect of the extra items of contract shall be completed within the 'period of final measurement' or within three months of the completion of the contract works as defined under clause (Certificate of Virtual Completion)

## **12. EXTRA ITEMS RATES**

The work or extra items shall be started only after the approval of extra items rates by client / Architect. Rates for additional or extra items work which cannot be derived from the contract item rates shall be calculated on the basis of actual cost plus 15 % for profit.

## **13. DRAWINGS AND INSTRUCTIONS**

A set of major drawings along with the contract documents shall be provided to the contractor. For any clarifications or further drawings are required by the contract, during or before the start of construction work, the Contractor shall inform the employer/Architects in writing to provide the same. Working details will be given to the contractor from time to time during the progress of work as and when required. In case of other drawing is required by the contractor he will give a minimum ten days notice to the Employer / Architect.

## **14. FAILURE BY CONTRACTOR COMPLY WITH ARCHITECT EMPLOYER'S INSTRUCTIONS**

If the contractor after receipt of written notice from the employer/architect requiring compliance with such further drawings and / or instruction, fails within seven days to comply with the same, the Employer / Architect may employ and pay other persons to execute any such work whatsoever as may be necessary to give effect thereto and all cost incurred in connection there with shall be recoverable from the contractors by the Employer as a debit or may be deducted from any money due or which become due to the Contractors.

## **15. INFORMATION TO BE SUPPLIED BY THE CONTRACTOR**

The contractor shall furnish the Employer / Architect the following:

- a) Detailed industrial statistics regarding the labor employed by him etc
- b) The Power of Attorney, name and signature of his authorized representative who will be in charges for the execution of work

- c) The list of technically qualified persons employed by him for the execution of this work.
- d) The total quantity and quality of materials used for the works.
- e) The list of plant and machinery employed for this work.

#### **16. ARCHITECT'S DELAY IN PROGRESS**

The Architect may delay the progress of the works in case of rains or otherwise, without vitiating the contract and grant such extension of time with the approval of the employer for the completion of the contract as he may think proper and sufficient in consequences of such delay, and the contractor, shall not make any claim for compensation or damage in relation thereto.

#### **17. CERTIFICATE AND PAYMENTS**

The contractor shall be paid by the Employer from time to time, by installments under interim Certificates to be issued by the Architect and Bank/SBI/MS's Engineer to the contractor on account of the works executed by the contractor when in the opinion of the Architect, work to the approximate value, named in the Appendix as 'Value of work for interim Certificates' (or less at the reasonable discretion of the Employer / Architect) has been executed in accordance with this contract, subject however, to a retention of the percentage of such value need in the Appendix hereto mentioned as 'retention percentage for interim Certificates' until the total amount retained shall reach the sum named in the appendix as Total Retention money after which time the installments shall be up to the full value of the work subsequently so executed in the interim Certificate, such amount as he may consider proper on account materials delivered upon the site by the Contractor for use in the work.

And when the works have been virtually completed and the Architect shall have certified in writing that they have been completed, the contractor shall be paid in accordance with the Certificate issued by the Architect the sum of money named in the Appendix after satisfying themselves as 'Installment after Virtual Completion 'being a part of the said 'Total Retention Money'.

The Contractor shall be entitled to the payment of the final balance in accordance with the final Certificate to be issued in writing by the Architect at the expiration of the period refer to as ' The Defect Liability Period' in the Appendix hereto, from the date of Virtual Completion or as soon as after the expiration of such period as the work shall have been finally completed and all defect made good according to the true intent and meaning hereof, whichever shall happen, provided always that the issue by the Architect of any certificate during the progress of the works or after the completion shall not relieve the Contract from his liabilities in cases of fraud , dishonesty or fraudulent concealment relating to the works of materials or any matter dealt within the certificate, and in case of all defects and insufficiency in the works or materials which reasonable examination world have disclosed. No certificate of the Architect shall of itself be conclusive evidence that any works and materials to which it relates are in accordance with the contract.

The Architect shall have power to withhold any certificate if the works or any part thereof is not being carried out to his / employer satisfaction.

The Architect may by any Certificate make any correction in any previous Certificate, which shall have been issued by him.

#### **18. DELAYED PAYMENTS**

Any amounts payable by the Employer to the contractor in pursuance of any Certificate given by the Architect hereunder shall, if not paid within the 'Period of honoring of Certificate' no interest will be paid by the Employer.

#### **19. FORCE MAJEURE**

Neither party shall be held responsible by the other for breach of any condition of this agreement attributable to any 'Act of God' Act of state, lockout of control or any other reason, beyond the control of the parties and any

breach of clauses arising from much force majeure conditions as aforesaid shall not be regarded as a breach of the provision of this Agreement.

**20. INCOME-TAX**

Income Tax shall be deducted at source by the client from the contractor' interim and final bill payments as per Statutory Regulations.

**21. SITE MEETINGS**

A senior representative of the contractor shall attend weekly meetings at works site and in addition meetings as and when arranged by employer / Architect to discuss the progress of the work and sort out problems, if any and ensure that the work is completed in the stipulated time.

**22. SCHEDULE OF APPROXIMATE QUANTITIES AND RATE**

1. The quantities given herein are approximate and they are subjected to alterations omissions, deductions or additions as provided for in the conditions of this contract and do not necessarily show the actual quantities of the work to be done.

2. It is to be expressly understood that the measured work is to be taken net (notwithstanding) any custom or practice to the contrary according to the actual quantities when in place and finished according to the drawings or as may be directed from time to time by the employer and the cost calculated by measurements or weight, at the respective prices, without any additional charge for any necessary or contingent works connected there with. The rates quoted are for work in site and complete in every respects.

3. If any operation of work, which is specified in the respective items mentioned in the schedule of quantities, is not executed by the contractor then proportionately the rate quoted in the schedule shall be re-fixed.

**23. ACTION WHERE THERE IS NO SPECIFICATION**

In case of any class of work for which is there is no specification mentioned, the same will be carried out in accordance with the Indian Standards Specifications subject to the approval of the Employer / Architect.

**24. ACCIDENT AT SITE**

The contractor shall be responsible for the safety of persons employed by him on the works. This shall be without prejudice to the responsibility of the contractor under the Insurance Clause of the general conditions. Contractor shall take all precaution detailed in the safety code attached separately.

**25. TYPOGRAPHICAL CLERICAL ERRORS**

The Employer / Architect clarification regarding partially omitted particulars of typographical or Clericals errors shall be final and binding on the contractors.

**26. WORK PERFORMED AT CONTRACTOR'S RISK**

The contractor shall take all precautions necessary and shall be responsible for the safety of the work and shall maintain all lights, goods, signs, temporary passages or other protection necessary for the purpose. All works shall be done by the contractor's risk and if any loss or damage shall result from fire or from others cause, the contractor shall promptly repay or replace such loss or damage free from all expenses to the employer.

The contractor shall be responsible for any loss or damage to materials, tools or other articles used held for use in connection with the work. The work shall be carried on to completion without interferences with the operations of existing machinery or equipment, if any.

**27. SPECIAL CONDITIONS OF CONTRACT**

In the event of any discrepancy with clauses mentioned anywhere else in the tender with the clauses mentioned within special conditions of contract, the clauses mentioned within the special conditions of contract shall supersede those mentioned elsewhere.

## **28. CONTRACTOR'S LABOUR REGULATIONS**

Short title:

1. These regulations may be called the "contractor labour regulations."
2. **Definitions :-** in these regulations, unless otherwise expressed or indicated, the works and expressions shall have the meaning hereby assigned to them respectively, that is to say :
  - (i) "Labour" means worker employed by the Bank/SBI/MS's contractor directly or indirectly through a sub-contractor or other persons or by an agent on his behalf of a payment not exceeding Rs. \_\_\_\_\_/- per month and will not include supervisory staff like overseers etc.
  - (ii) "fair wages" means wages whether for time or piece work notified at the time of inviting tenders for the work and where such wages prescribed by the government of India in the ministry of labour and employment vide Sl.No. 1917 published in the gazette of India, extraordinary part - ii section (3) sub-section (ii) dated 19-5-1969.
  - (iii) "contractors" shall include every person whether a sub-contractor or headman or agent employing labour on the work taken on contract.
  - (iv) "Wages" shall have the same meaning as defined in the payment of wages act and includes time and piece rate wages.
2. a. Normally working hours if an adult employee should not exceed 9 hours a day and in case of a child 4 1/2 hours a day. The working day shall be so arranged that inclusive of interval for rest, if any, it shall not spread over more than 12 hours on any day.
- 2.b. When an adult worker is made to work for more than 9 hours on any day or for more than 48 hours in any week. he shall be paid overtime for the extra hours put in by him at double the ordinary rate of wages. Children shall not be made to work extra.
- 2.c. Every worker shall be given a paid weekly holiday normally on Sunday in accordance with the provisions of minimum wages (central) rules, 1960 as amended from time to time irrespective of whether such worker is governed by the minimum wages act 1948 or not.
- 3 **Display of notice regarding wage etc. the contractor shall:**
  - (a) Before the commences his work on contract, display and correctly maintain and continue to display correctly maintain in a clean legible condition in conspicuous places on the work, notice in English and in the local Indian language spoken by the majority of workers, giving the rate of wages which have been certified by the executive engineer, ZONAL labour commissioner fair as wages and the hours of work for which such wages are earned, and
  - (b) Send a copy of such notices to the certifying officer.
2. **Payment of wages under central govt. wages act:-**
  - (i) Wages due to every worker shall be paid to him direct.
  - (ii) All wages shall be paid in current coin or currency or in both.
  - (iii) Arrears claimed after 3 months after the completion of the work shall not be entertained.
3. **Fixation of wage periods:-**
  - (i) The contractor shall fix the wage periods in respect of which the wages shall be payable.



The minimum daily rates of wages fixed under notification of the government of India in the ministry of labour and employment no. 1972 dated 10-5-78 are inclusive of wages for weekly day of restyle and the question of extra payment for week holiday would not arise.

- (ii) No wage period shall exceed one month.
- (iii) wages of every employed on the contract shall be paid (a) in case of establishments in which wage period is one week within 3 days from the end of the wage period and (b) in the case of other establishments before the expiry of the 7th day or 10th day from the end of the wages period according to the number of workers employed in such establishment does not exceed 1000 or exceeds 1000.
- (iv) When the employment of any worker is terminated by or on behalf of the contractor the wages earned by him shall be paid before the expiry the day exceeding the one on which his employment is terminated.
- (v) All payment of wages shall be made on a working day except when the work is completed before the expiry of the wage period in which case final payment shall be made within 48 hours of the last working day at work site and during the working time.

**Note:** The term "working day" means a day on which work on which the labor employed is in progress.

- 6. wage book and wage slips etc. :** the contractor shall maintain a wage book of each worker in such form as may be convenient at the place of work, but the same shall include the following particulars :-
- (a) Name of the worker.
  - (b) Rate of daily or monthly wages.
  - (c) Nature of work on which employed.
  - (d) Total number of days worked during each wage period.
  - (e) Dates and periods for which worked overtime.
  - (f) Gross wages payable for the work during each wage period.
  - (g) All deductions made from the wage with an indication in each case of the ground for which the deduction is made.
  - (h) Wages actually paid for each wage period.
  - (i) Signature or thumb impression of the worker.
  - (j) The contractor shall also issue a wage slip containing the aforesaid particulars to each worker employed by him on the work at least a day prior to the day of disbursement of wages.
  - (k) The contractor shall issue the employment card in the prescribed form iii to each worker on the day of work or entry in to his employment. If the worker has already any such card with him from the previous employer, the contractor shall merely endorse that employment card with relevant entries. On termination of employment the employment card shall again be endorsed by the contractor and returned to the worker.
  - (l) **The contractor shall issue an attendance-cum-wages card as perform:**  
Attached to each worker on the day of each worker on entry into his employment.
- 7. Register of unpaid wages: –** the contractor shall maintain a register of unpaid wages in such form as may be convenient at the place of work but the same shall include the following particulars:
- (a) Full particulars of the laborers where wages have not been paid.
  - (b) Reference number of the muster roll and wage register.
  - (c) Rate of wages.
  - (d) Wage period
  - (e) Total amount not paid
  - (f) Reasons for not making payment
  - (g) How the amount of unpaid wages was utilized.
  - (h) Acquaintance with dates.
- 8. Register of accidents:** the contractor shall maintain a register of accidents in such form as may be convenient at the work place but the same shall include the following particulars:
- (a) Full particulars of the laborers who met with accident.

- (b) Rate of wages.
- (c) Sex
- (d) Age
- (e) Nature of accident and cause of accident.
- (f) Time and date of accident
- (g) Date and time when admitted in hospital
- (h) Date of discharge from the hospital
- (i) Period of treatment and result of treatment.
- (j) Percentage of loss of earning capacity and disability as assessed by the medical officer.

- (k) Claim required to be paid under worker's compensation act.
- (l) Date of payment of compensation.
- (m) Amount paid with details of persons to whom the same was paid.
- (n) Authority by whom the compensation was assessed.
- (o) Remarks.

**9. Fines and deductions which may be made from wages:**

- (i) The wages of a worker shall be paid to him without any deduction of any kind except the following:
  - (a) Fines.
  - (b) Deduction for absence from duty i.e. from the place or the places whereby terms of his employment he required to work. The amount of deduction shall be in proportion to the period for which he was absent.
  - (c) Deduction for damage to or loss of goods expressly entrusted to the employed person for custody, or loss of money or any other deduction which he is required to account, where such damage or loss is directly attributable to this neglect or default.
  - (d) Deduction for recovery of advances or for adjustment of over-payment of wages, advance granted shall be entered in a register.
  - (e) Any other deduction which the central government may from time to time allow.
  - (ii) No fine should be imposed on any worker save in respect of such acts and omission on his part as have been approved by the chief labour commissioner.
  - (iii) No fine shall be imposed on a worker and no deduction for damage or loss shall be made from his wages until the worker has been given an opportunity of showing cause against such fines or deductions.
  - (iv) The total amount of fine which may be imposed in any one wage period on a worker shall not exceed an amount equal to three paise in a rupee of wages, payable to him in respect of that wage period.
  - (v) No fine imposed on any worker shall be recovered from him by installment, or after the expiry of sixty days from the date on which it was imposed.
  - (vi) Every fine shall be deemed to have been imposed on the day of the act or omission in respect of which it was imposed.

**10. Register of fines, etc.:**

- (i) The contractor shall maintain a register of fines and a register of deduction for damage or loss in form nos. 1 & 2 respectively which should be kept at the place of work.
- (ii) The contractor shall maintain both in English and the local Indian language, a list approved by the chief labour commissioner clearly stating the acts and omissions for which penalty or fine may be imposed on a workman and display it in a good condition in a conspicuous place of the work.

**11. Preservation of registers:** – the wage book the wage slips, the register of unpaid wages, the register of accidents, the register of fines, deductions required to be maintained under these regulations shall be preserved for 45 days after the date of last entry made in them and shall be made available for inspection by the engineer-in-charge labour welfare officer or any other officer authorized by the chief labour commissioner in this behalf.

**12. Powers of labour welfare officer to make investigation or enquiry**

The labour welfare officer or any other person authorized by the central government on their behalf shall have power to make enquiries with a view to ascertaining and enforcing due and proper observance of the fair wage clauses and provisions of these regulations. He shall investigate into any complaint regarding the default made by the contractor or sub-contractor in regard to such provision.

**13. Report of labour welfare officer**

The labour welfare officer or other persons authorized as aforesaid shall submit a report of result of his investigation or enquiry to the executive engineer concerned indicating the extent, if any, to which the

default has been committed, with a note that necessary deduction from the contractor's bill be made and the wages and other dues be paid to the laborers concerned. In case an appeal is made by the contractor under clause 14 of these regulations actual payment to the laborers will be made by the executive engineer after the zonal labour commissioner has given his decision on such appeal.

- (a) The executive engineer shall arrange payments to the labors concerned within 45 days from the receipt of the report from the labour welfare officer or the zonal labour commissioner as the case may be.

**14. Appeal against the decision of labour welfare officer:**

Any person aggrieved by the decision and recommendations of the labour welfare officer or other person so authorized may appeal against such decision to the zonal labour commissioner concern within 30 days from the date of decision, forwarding simultaneously a copy of his appeal to the executive engineer concerned but subject to such appeal, the decision of the officer shall be final and binding upon the contractor.

**15. Prohibition regarding representation through lawyer:**

(a) A workman shall be entitled to be represented in any investigation or enquiry under this regulation by:

- (a) An officer of a registered trade union of which he is a member.
- (b) An officer of a federation of trade unions to which the trade union referred to in clause (a) is affiliated.
- (c) Where the employee is not a member of any registered trade union, by any officer, of a registered union, connected with, or by any other workman, employed in the industry in which the worker employed.

(ii) An employer shall be entitled to be represented in any investigation or enquiry under this regulation by;

- (a) An officer of any association of employers of which he is a member.
- (b) An officer of a federation of association of employers to which the Association referred to in clause (a) is affiliated.
- (c) Where the employer is not a member of any association of employers' by an officer of association of employers connected with or by any other employer, engaged in the industry in which the employer is engaged.

(iii) No party shall be entitled to be represented by a legal practitioner in any investigation or enquiry under these regulations.

**16. Inspection of books and slips:**

The contractor shall allow inspection of the wage books and the wage slips the register of unpaid wages, the register of a accident, and the register of fines and deduction to any of his workers or to his agent at a convenient time and place after due notice is received or to the labour welfare officer or any other person authorized by the central government on his behalf.

**17. Submission of returns:**

The contractor shall submit periodical returns as may be specified from time to time.

**18. Amendment:** the central government may from time to time add to or amend the regulation and on any question as to the application, interpretation or effect of these regulations the decision of the chief labour commission or deputy chief labour commission to the government of India, or any other person authorized by the central government in that behalf shall be final.

**32. Safety code**

**Scaffolds:**

- (i) Suitable scaffolds should be provided for workmen for all works that cannot safely be done from the ground, or from solid construction except such short period work as can be done safely from ladders. when a ladder is used an extra mazdoor shall be engaged for holding the ladder and if the ladder used for carrying material as will, suitable footholds and hand holds shall be provided on the ladder and the ladder shall be given an inclination not steeper than 1/4 to 1 (1/4) horizontal and 1 vertical)
- (ii) Scaffolding or staging more than 4m. above the ground or floor, swung or suspended from an overhead support or erected with stationary support shall have a guard rail properly attached bolted, braced and otherwise secured at least 3 feet high above the floor or platform of such scaffoldings or staging and extending along the entire length of the outside and ends there of with only such opening as may be necessary for the delivery of materials. Such scaffolding or staging shall be so fastened as to prevent it from swaying from the building or structure.
- (iii) Working platform, gangways, and stairways should be so constructed that they should not sag unduly or unequally, and if the height of the platform or the gangway or the stairway is more than 12 feet above the ground level on the floor level. They should be closely boarded, should have adequate width and should be suitably fastened, as described in (ii) above.
- (iv) every opening in the floor of a building or in a working platform be provided with suitable means to prevent the fall of persons or materials by providing suitable fencing or railing whose minimum height shall be -3'0". Wherever there are open excavations in ground, they shall be fenced off by suitable railing and danger signals installed at night so as to prevent persons slipping into the excavations.
- (v) Safe means of access shall be provided to all working platforms and the working places. Every ladder shall be securely fixed. No portable single ladder shall be over 9m. In length while the width between sides rail in rung ladder width shall in no case be less than 290mm. For ladder up to and including 3m. In length. For longer ladders this width should be increased at least 20mm. for each additional meter or length.
- (vi) A sketch of the ladders and scaffolds proposed to be used shall be prepared and approval of the engineer obtained prior to construction.

**Other safety measures**

- (vii) All personnel of the contractor working within the plant site shall be provided with safety helmets. All welders shall wear welding goggles while doing welding work and all metal workers shall be provided with safety gloves. Persons employed on metal cutting and grinding shall wear safety glasses.
- (viii) Adequate precautions shall be taken to prevent danger from electrical equipment. No materials on any of the sites of work shall be so stacked or placed as to cause danger or inconvenience to any person or the public.

**FORM OF AGREEMENT**

ARTICLES of AGREEMENT made this \_\_\_\_\_ day of \_\_\_\_\_ year 2018 between the **State Bank of India, P&E Deptt. LHO, Bhopal** (Hereinafter referred to as the "Employer/Owner/client" which expression shall, unless excluded by or repugnant to the context, includes its successors and assigns) of the ONE PART and of \_\_\_\_\_ (Hereinafter referred to as "Contractor" unless excluded by or repugnant to the context, includes its successors and assigns) of the OTHER PART.

WHEREAS the Employer through SBIIMS, intends to carry out Electrical & AC work of DSH BETUL, **shall herein after referred to as "Project"**.

AND WHEREAS for the purpose of the above said project, the SBIIMS PVT. Ltd., Circle Office, Bhopal invited sealed tenders on behalf of SBI from experienced, resourceful and bonafied contractors vide his Notice Inviting Tender (No. \_\_\_\_\_ dated. \_\_\_\_).

WHEREAS the contractor submitted his Tender Documents containing Notice Inviting Tender, General notes, General Conditions of Contract, Special conditions, Schedule of approximate quantities and rates , Form of Agreement, General Specification, Approved manufacturers/ natural source of materials, Declaration, Technical Specifications as in Schedule of Quantities etc. for the above said project, (Hereinafter collectively referred to as the "said conditions"), duly signed on each page as a token of his acceptance of the same, along with requisite **Earnest Money Deposit**.

AND WHEREAS out of the Tenders received, the Tender of the contractor was found to be most suitable for the project.

AND WHEREAS the SBIIMS has accordingly issued the work order (No. \_\_\_\_\_ dt. \_\_\_\_\_) to the contractor subject to his furnishing the requisite Security Deposit.

AND WHEREAS the Contractor has accepted the aforesaid Work Order vide his letter of acceptance NO. dt. \_\_\_\_\_ and has also deposited with the Employer a sum of Rs. \_\_\_\_\_ which with the Earnest Money of RS. \_\_\_\_\_ forms the requisite Security Deposit @ 2 % of the accepted Tender Value of Rs. \_\_\_\_\_.

NOW, therefore, it is hereby agreed to and between the parties as follows:

1) Contract documents

The following documents shall constitute the Contract Documents.

- I. This Article of Agreement.
- II. Tender Document submitted by the Contractor including the "said conditions", N.I.T and Schedule of quantity.
- III. All correspondence between the Employer and the Contractor from the date of issue of N.I.T and the date of issue of work order.
- IV. Work order No. \_\_\_\_\_ dt. \_\_\_\_\_

2) In consideration of the payments to be made to the Contractor as hereinafter provided the Contractor shall upon and subject to the said conditions, execute and complete the contracted project works shown upon the said drawings etc. and such further detailed drawings as may be furnished to the contractor by the said SBIIMS and described in the said Specifications and the said Schedule of Quantities.

3) Notwithstanding what are stated in the N.I.T conditions of Tendering, Conditions of Contract of herein stated before, the Employer reserves itself the right of altering the drawings and the nature of the work and addition to or omitting any items of work or of having portions of same carried out departmentally or otherwise and such alterations or variations shall be carried out without prejudice to this contract.

4) As mentioned in Article 1 above, the “said conditions” shall be read and be treated as forming part of this agreement and parties hereto will respectively be bound thereby and to abide by and submit themselves to the conditions and stipulations and perform the same on their parts to be respectively observed and preferred.

5) Any dispute arising under this agreement shall be referred to the Arbitration in a manner specified in the General Conditions of the Contract and all legal disputes shall be limited within the territorial jurisdiction of the Bhopal thereto. The decision of the arbitration shall be final and binding on both the parties.

IN WITNESS WHEREOF THE PARTIES to their present have here under set and subscribed their hands, the day, month and year first above written.

Signed and delivered for and on behalf of

**State Bank of India**, Shri. \_\_\_\_\_ its duly authorized official, In the presence of

—

1. (Name and Address)

2. (Name and Address)

**SBI Infra Management Solutions Pvt. Ltd.,**

1. (Name and Address)

2. (Name and Address)

Signed and delivered for and on behalf of

**The Contractor** \_\_\_\_\_ by Shri \_\_\_\_\_ his duly authorized official, in the presence of –

1. (Name and Address)

2. (Name and Address)

READ, UNDERSTOOD AND ACCEPTED

**SIGNATURE OF THE CONTRACTOR WITH SEAL**

DATE

**LIST OF MATERIALS OF APPROVED BRAND AND THEIR MANUFACTURERS****APPROVED MAKE OF MATERIAL FOR ELECTRICAL WORK**

<b>S.No</b>	<b>Description of Items</b>	<b>Make of Material</b>
1	Modular type 6/16/32 amp switch, socket, step electronic fan regulator 250 Volt, cover plate, box, bulb holder, 3 pin ceiling rose,TV/Telephone socket with all accessories	Legrand/ Anchor(Roma)/MK/Crabtree
2	MCCB( 25 KA) breaking capacity	Legrand/Hagger/Siemens/Schneider
3	MCCB/ELCB (10 KA) breaking capacity	Legrand/Hagger/Siemens/Schneider
4	MS steel/PVC Conduit with accessories	AKG/BEC/NIC/Precision
5	DBs ( IP 43)	Legrand/Hagger/Siemens/Schneider
6	PVC insulated copper wire(FR) 650V/1100Volt grade	Finolex/Havells/RR cable
8	PVC/XLPE insulated Al./Cu. Armoured cable 1100 Volt Grade	Finolex/Havells/RR cable/ C.C.I( Cable Corp. Of India)
9	Telephone wire/cable	Finolex/Delton
10	Data cable, Cat-6 cable, Switch, Jack Panel, Rack, Patch cords, Computer I/Os and other accessories	D-link, Legrand
11	Switch Fuse Unit(SFU)	L&T/ Siemens/Schneider
12	Contactors	L&T/ Siemens/Schneider
13	Meters	L&T/Conserve/Elmeasure
14	Cable Termination	Dowells/Comet
15	Cable Tray	Profab/Metalemms/Asian Ancillary Corporation
16	Light Fixture	Philips/Wipro/Crompton Greaves/Havells
17	Ceiling Fan/Wall Fan	Orient/Usha/Crompton Greave/Havells
18	Exhaust Fan	Crompton Greave/Almonard/Alstom/Usha/Havells
19	Amplifier/Speakers	Bosch/Ahuja
20	Sensors(Occupancy)	Honeywell(MK)/ Siemens/Johnson control



NIT NO. **BHO202004031**

21	Panel	As per IS standard/ CPRI Tested
<b>APPROVED MAKE OF AIR CONDITIONING WORKS</b>		
	Air Conditioners	Daikin/ Hitachi/ Voltas/Bluestar/ Carrier
	Drain Pipe	Kasta/ Supreme/Astral/Finolex
	Voltage Stabilizer	Microteck, V-Gard
	Timer	Legrad/L&T other eq. ISI make
<p>Note:- All the material to be ISI marked. The material shall be only of the approved make only as specified as above. The Contractor shall submit samples of all the makes as specified in above specified makes and the Bank shall have the power to select any of them. The Bank's decision in this regard shall be binding on the contractor. In case any material is not available for any one or all of the above approved make the Bank's shall select and approve alternative makes. The contractor is binding to arrange that material. The LT panel as per IS standard/CPRI Tested.</p>		

Seal & Signature of the contractor

- IB.
- 1) The contractor should obtain prior approval from Employer / Consultants before placing order for any specific materials. Employer may / delete any of the makes or brands out of the above list.
  - 2). All materials should conform to relevant standards and codes of BIS.
  - 3) Materials with I.S.I. mark shall be used duly approved by the SBIIMS Engineer / Architect.

**Note: - If any material is found to be not up to the mark, the contractor will have to produce original bills/certificate from the manufacturer or his authorised Distributor for authenticity and genuineness of the material for consideration and as per make approved by the SBIIMS. The same will not be considered for payment.**

## TECHNICAL SPECIFICATIONS FOR ELECTRICAL AND AC WORKS

### CHAPTER : I GENERAL

1. All works shall be carried out as per accepted standard and as per IS: Specifications.
2. All materials, fittings, accessories etc. for use in electric installation shall be as per approved list of material attached, unless otherwise specified. In the case of materials for which no specific make is approved or specified the same shall confirm to relevant Indian Standard Specification and/or shall be approved by the SBIIMS Engineer in Charge.
3. In general, circuit wiring is to be done in separate conduits and not in point wiring conduits.
4. Wiring shall be done only in steel conduit system.
5. 2x1.5 Sqmm (22/0.3mm) multi stranded denotes 2 wires of 1.5 Sqmm. (22/0.3mm) multi stranded and so on for other sizes.
6. In case where metric size/rating materials is/are not available, equivalent British size/rating shall be permitted to be used with the written approval of the Consultant.
7. In point wiring for light points where bulkhead is provided in place of ceiling rose/batten holder, Rs.16.00 per point to be deducted ( - ).
8. Blanking plates shall be provided in the MCB distribution board in the blank unused ways, where MCBs are not provided, no extra payment to be allowed for the same, and if blanking plate not provided Rs.3/- per plate (per way) to be deducted from the rates of MCB enclosures ( - ).
9. The rates given in this schedule, are for the finished work covering cost of all materials, labour, royalties, lease rent, wastage temporary work, hire charges of tools and plant, equipment and machinery required to complete the work, over head charges and profit etc. unless specified other wise.
10. In case of any contradiction in the provision of the specifications and Schedule of rate, the provision of the latter would take precedence.
11. In booking dimensions, the order shall be consistent and generally in the sequence of length, width and height or depth or thickness.
  13. The following tolerance shall be permitted in measurement unless stated otherwise. Any work done extra over the specified dimensions shall be ignored. Tolerances for areas and cubic contents are applicable only for Civil Works associated with the electrical work:
    - (a) Dimension shall be measured to the nearest 0.05 M.
    - (b) Areas shall be worked out in the nearest 0.01 Sqm.
    - (c) Cubic contents shall be worked out to the 0.01 Cum.
14. The agency carrying out the work shall certify that the work has been carried out as per statutory or other regulations in force and prescribed specifications.
15. The materials and labour involved shall be described and it shall be stated that the materials used are of approved make of the Board and as per list attached to the agreement/NIT etc.
16. The provision of scaffolding or ladder or any tools and plants required shall be deemed to be included in the item, unless otherwise stated.
17. Cutting through walls and floors lifting up floor boards and refixing cutting out plaster and making good all the work disturbed, notching or drilling holes through joists etc. shall be deemed to be included with the item of work.
18. The work shall be strictly carried out in accordance with the detailed layout plan of Electrical installation unless otherwise necessary to be altered due to site conditions during the course of execution.
19. Completion plans for the installation carried out shall be furnished.
20. Method and type of wiring shall be fully described and measured separately, it shall be classified according to the size and types of cables used.
21. Concealed conduit work and surface conduit work shall also be classified and described separately the former shall include embedding the conduit and allied fitting in walls, floors etc. during constructions or cutting chases, or both and making good as necessary.
22. Point wiring shall include all work necessary in complete wiring of any length via a switch :
  - (a) Ceiling rose or connector (in case of ceiling and exhaust fan points or stiff pendent).
  - (b) Ceiling rose (in case of pendent points except stiff pendent points).
  - (c) Lamp holder (in case of wall brackets, batten points bulk head fittings and similar other fittings).
  - (d) Call bell or Buzzer (in this case the words "Via the switch" shall be read as "Via the bell push or ceiling rose" as the case may be.

**NIT NO. BHO202004031**

- (e) Upto Electric Clock outlet.
- (f) Upto socket outlet.

22.1 When there is only one point on the distribution circuit (one way), the same shall be measured in two parts as circuit wiring according to the definition of the circuit wiring and the other as "Points" according to the above definition for "Points".

22.2 The following shall be deemed to be included in the Point Wiring.

- (a) Rigid steel conduit/rigid PVC non-metallic conduit/casing and capping/batten as the case may be, accessories for the same and wiring cables from controlling switch or any other type of switch to the point with ferrule numbering.
- (b) Switch and ceiling rose or connector or batten holder with special and suitable round block for neatly housing the connector as required.
- (c) In case of wall brackets, bulk head fitting and similar fittings, cable as required upto the Lamp Holder.
- (d) Bushed conduit or porcelain tubing when cables pass through wall etc.
- (e) Earth wire from 3 pin socket point to the common earth including connection to the pin of 3/5 pin socket outlet except earth wire from the first tapping of live wire to the sub distribution board.
- (f) All PVC/Wooden/Metal blocks switch boards and boxes sunk or surface type, with suitable covering, (Phenolic laminated sheet) including those required for mounting fan regulator but excluding those under the distribution board and main control switch.
- (g) All fixing accessories such as clips, nails, screws, phil plug, rawl plug, wooden plug etc. as required.
- (h) Joint for junction boxes and connecting the same as required.
- (i) Connections to ceiling rose or connector, socket outlet, lamp holder, fan regulator etc.
- (j) Socket outlets as specified.
- (k) Inter connection wiring between points on the same circuits in same switch box or from another.
- (l) Connector as required for looping of wiring for two or more wires wherever required.
- (m) Pendants, if provided shall be paid extra.
- (n) All the switches, socket, plate, boxes, blank plate and regulator to be modular plate type.

22.3 The mechanical protection provided to the wiring coming within 1.5 Mtr. from floor level upto switch board shall be deemed to have been included in the item of work. Method of installation and making good the damages shall be described in the specification.

22.4 The common earth continuity conductor shall be described stating material size and method of installation.

23.3 Any junction box provided for extending the wiring beyond the point referred to shall not be treated as the nearest tapping point.

## **CHAPTER: II**

### **METALLIC CONDUIT WIRING SYSTEM**

#### **2.0 SCOPE**

This chapter covers the detailed requirements for wiring work in metallic conduits. This chapter covers both surface and recessed types of works.

#### **2.1 APPLICATION**

- (i) Recessed conduit is suitable generally for all applications. Surface conduit work may be adopted in places like workshops, plant rooms, pump rooms, wiring above false ceiling/below false flooring and at locations where recessed work may not be possible to be done. The type of work viz. surface or recessed shall be as specified in the respective works.
- (ii) Flexible conduits may only be permitted for inter connections between switch gear, DB's and conduit terminations in wall.

#### **2.2 MATERIALS**

##### **2.2.1 Conduits**

- (i) All rigid conduit pipes shall be of steel and be ISI marked. The wall thickness shall be not less than 1.6mm (16 SWG) for conduits upto 32mm dia and not less than 2mm (14 SWG) for conduits above 32mm dia. These shall be solid drawn or reamed by welding and finished with galvanized or stove enamelled surface.

## NIT NO. BHO202004031

(ii) The maximum number of PVC insulated cables conforming to IS:694-1990 that can be drawn in one conduit is given sizewise in Table-1 and the number of cables per conduit shall not be exceeded. Conduit sizes shall be selected accordingly in each run.

(iii) No steel conduit less than 20mm in diameter shall be used.

### 2.2.2 Conduit accessories

(i) The conduit wiring system shall be complete in all respects including their accessories.

(ii) All conduit accessories shall be of threaded type and under no circumstances pin grip type or clamp grip type accessories shall be used.

(iii) Bends couplers etc. shall be solid type in recessed type of works and may be solid or inspection type as required, in surface type of works.

(iv) (a) Saddles for surface conduit work on wall shall not be less than 0.55mm (24 gauge) for conduits upto 25mm dia and not less than 0.9mm (20 gauge) for largest diameter. The corresponding widths shall be 19mm and 25mm.

(b) The minimum width and the thickness of girder clips used for fixing conduits to steel joists, and clamps shall be as per Table-II.

### 2.2.3 Outlets

(i) The switch box or regulator box shall be made of metal on all sides, except on the front. In case of welded mild steel sheet boxes, the wall thickness shall not be less than 1.2mm (18 gauge) for boxes upto a size of 20cm X 30cm and above this size 1.6mm (16 gauge) thick MS boxes shall be used. The metallic boxes shall be duly painted with anticorrosive paint before erection as per Specifications.

(ii) GI earth terminal with stud and 2 G.I. washers shall be provided in each MS box for termination of protective conductors and for connection to socket outlet/metallic body of fan regulator etc.

(iii) A metal strip shall be welded/screwed, to the metal box as support if tumbler type of control switches, sockets and/or fan regulators are to be fixed therein.

(iv) Clear depth of the box shall not be less than 50/60 mm and this shall be increased suitably to accommodate mounting of fan regulators in flush pattern.

(v) The fan regulators can also be mounted on the switch box covers, if so stipulated in the tender specifications, or if so directed by the Engineer- in-Charge.

(vi) Except where otherwise stated, 3mm thick phenolic terminated sheets shall be fixed on the front with brass screws, or aluminum alloy/cadmium plated iron screws as approved by the Consultant.

## 2.3 INSTALLATION

### 2.3.1 Common aspects for recessed and surface conduit works

#### (i) Conduit Joints

(a) The conduit work of each circuit or section shall be completed before the cables are drawn in.

(b) Conduit pipes shall be jointed by means of screwed couplers and screwed accessories only.

Threads on conduit pipes in all cases shall be between 13mm to 19mm long sufficient to accommodate pipes to full threaded portion of couplers or accessories.

(c) Cut ends of conduit pipes shall have no sharp edges, nor any burrs left to avoid damage to the insulation of the conductors while pulling them through such pipes.

(d) The Consultant, with a view to ensuring that the above provision has been carried out, may require that the separate lengths of conduit etc. after they have been prepared, shall be submitted for inspection before being fixed.

(e) No bare threads portion of conduit pipe shall be allowed unless such bare threaded portion is treated with anticorrosive pipe servative or covered with approved plastic compound.

#### (ii) Bends in conduit

(a) All necessary bends in the system, including diversion, shall be done either by neatly bending the pipes without cracking with a bending radius of not less than 7.5cm or alternatively, by inserting suitable solid or inspection type normal bends, elbows or similar fittings, or by fixing cast iron inspection boxes, whichever is most suitable.

(b) No length of conduit shall have more than the equivalent of four quarter bends from outlet to outlet.

(c) Conduit fittings shall be avoided as far as possible on conduit system exposed to weather. Where necessary, solid type fittings shall be used.

**NIT NO. BHO202004031**

(iii) Outlets

(a) All outlets such as switches, wall sockets etc. may be either flush mounting type, or of surface mounting type, as specified in the Additional Specifications.

(iv) Painting after erection

After installation, all accessories of conduit pipes, fittings, switch and regulator boxes etc. shall be painted.

**2.3.2 Additional requirements for surface conduit work**

(i) Painting before erection

The outer surface of conduit including all bends, unions, tees, junction boxes, etc. forming part of the conduit system, shall be adequately protected against rust when such system is exposed to weather, by being painted with 2 coats of red oxide paint applied before they are fixed.

(ii) Fixing conduit on surface

(a) Conduit pipes shall be fixed by saddles, secured to suitable approved plugs with screws in an approved manner at an interval of not more than one metre, but on either side of the couplers or bends of similar fittings, saddles shall be fixed at a distance of 45 cm from the centre of such fittings.

(b) Where conduit pipes are to be laid along the trusses steel joists etc. the same shall be secured by means of saddles or girder clips or clamps as required by the Consultant.

(c) In long distance straight run of conduit, inspection type couplers at reasonable intervals shall be provided, or running threads with couplers and jamnuts shall be provided.

(iii) Fixing outlet boxes

Only a portion of the switch box shall be sunk in the wall, the other portion being projected out for suitable entry of conduit pipes into the box.

**2.3.3 Additional requirements for recessed conduit work**

(i) Making chase

(a) The chase in the wall shall be neatly made, and of ample dimensions to permit the conduit to be fixed in the manner desired.

(b) In the case of buildings under construction, the conduits shall be burried in the wall before plastering, and shall be finished neatly after erection of conduit.

(c) In case of exposed brick/rubble masonry work, special care shall be taken to fix the conduit and accessories in position along with the building work.

(ii) Fixing conduits in chase

(a) The conduit pipe shall be fixed by means of stapples, J-hooks or by means of saddles, not more than 60cm apart, or by any other approved means of fixing.

(b) All threaded joints of conduit pipes shall be treated with some approved preservative compound to secure protection against rust.

(iii) Fixing conduits in 'RCC work'

(a) The conduit pipes shall be laid in position and fixed to the steel reinforcement bars by steel binding wires before the concreting is done. The conduit pipes shall be fixed firmly to the steel reinforcement bars to avoid their dislocation during pouring of cement concrete and subsequent tamping of the same.

(b) Fixing of standard bends or elbows shall be avoided as far as practicable, and all curves shall be maintained by bending the conduit pipe itself with a long radius which will permit easy drawing in of conductors.

(c) Location of inspection/junction boxes in RCC work should be identified by suitable means to avoid unnecessary chipping of the RCC slab subsequently to locate these boxes.

(iv) Fixing inspection boxes

(a) Suitable inspection boxes to the minimum requirement shall be provided to permit inspection and to facilitate replacement of wires, if necessary.

(b) These shall be mounted flush with the wall or ceiling concrete. Minimum 65mm depth junction boxes shall be used in roof slabs and the depth of the boxes in other places shall be as per IS:2667-1977.

(c) Suitable ventilating holes shall be provided in the inspection box covers.

(v) Fixing switch boxes and accessories

Switch boxes shall be mounted flush with the wall. All outlets such as switches, socket outlets etc. shall be flush mounting type, unless otherwise specified in the Additional Specifications.

(vi) Fish wire

To facilitate subsequent drawing of wires in the conduit. GI fish wire of 1.6mm/1.2mm (16/18 SWG) shall be provided alongwith the laying of the recessed conduits.

(vii) Bunching of cables

**NIT NO. BHO202004031**

(a) Cables carrying direct current may, if desired, be bunched whatever their polarity, but cables carrying alternating current, if installed in metal conduit shall always be bunched so that the outgoing and return cables are drawn into the same conduit.

(b) Where the distribution is for single phase loads only, conductors for these phases shall be drawn in one conduit.

(c) In case of three phase loads, separate conduits shall be run from the distribution boards to the load points, or outlets as the case may be.

**2.3.4 Earthing requirements**

(i) The entire system of metallic conduit work, including the outlet boxes and other metallic accessories, shall be mechanically and electrically continuous by proper screwed joints, or by double checknuts at terminations. The conduit shall be continuous when passing through walls or floors.

(ii) Protective (loop earthing) conductor(s) shall be laid along the runs of the conduit between the metallic switch boxes and the distribution boards/switch boards, terminated thereto. These conductors shall be of such size and material as specified. Depending upon their size and material, the protective earth conductors shall be either drawn inside the conduits along with the cables, or shall be laid external to

the conduits. When laid external to the conduits, this shall be properly clamped with the conduit at regular intervals.

(iii) The protective conductors shall be terminated properly using earth studs, earth terminal block etc. as the case may be.

(iv) Gas or water pipe shall not be used as protective conductor (earth medium).

**TABLE - I**

Max. number of PVC insulated 650/1100 V grade aluminium/copper conductor cable conforming to IS:694-1990

Nominal cross sectional area of conductor in Sqmm.	20mm		25mm		32mm		38mm		51mm		64mm	
	S	B	S	B	S	B	S	B	S	B	S	B
1	2	3	4	5	6	7	8	9	10	11	12	13
1.50	5	4	10	8	18	12	--	--	--	--	--	--
2.50	5	3	8	8	12	10	--	--	--	--	--	--
4	3	2	6	5	10	8	--	--	--	--	--	--
6	2	--	5	4	8	7	--	--	--	--	--	--
10	2	--	4	3	5	5	8	6	--	--	--	--
16	--	--	2	2	3	3	6	5	10	7	12	8
25	--	--	--	--	3	2	5	3	8	6	9	7
35	--	--	--	--	--	--	3	2	6	5	8	6
50	--	--	--	--	--	--	--	--	5	3	6	5
70	--	--	--	--	--	--	--	--	4	3	5	4

Note:

1. The above table shows the maximum capacity of conduits for a simultaneous drawing in of cables.

2. The columns headed 'S' apply to runs of conduit which have distance not exceeding 4.25 m between draw in boxes and which do not deflect from the straight by an angle of more than 15 degrees columns headed 'B' apply to runs of conduit which deflect from the straight by an angle of more than 15 degrees.

3. Conduit sizes are the nominal external diameter.

**TABLE – II Girder Clips or clamps**

(Clause 2.2.2(iv))

Size of conduit	Width	Thickness
(i) 20mm	19mm	0.9mm (20 SWG)
(ii) 25mm	19mm	0.9mm (20 SWG)
(iii) 32mm and above	25mm	1.2mm (18 SWG)

**CHAPTER: III**

**TESTING OF INSTALLATION**

3.0 SCOPE

This chapter describes the details of tests to be conducted in the completed internal electrical installations, before commission.

3.1 GENERAL

3.1.1 Tests

On completion of installation, the following tests shall be carried out:

1. Insulation resistance test.
2. Polarity test of switch.
3. Earth continuity test.
4. Earth electrode resistance test.

3.1.2 Witnessing of tests

Testing shall be carried out for the completed installations, in the presence of and to the satisfaction of the Consultant by the contractor. All test results shall be recorded and submitted to the Department.

3.1.3 Test instruments

All necessary test instruments for the tests shall be arranged by the contractor if so required by the Consultant.

3.2 INSULATION RESISTANCE

3.2.1 The insulation resistance shall be measured by applying between earth and the whole system of conductors, or any section thereof with all fuses in place, and all switches closed, and except in earthed concentric wiring, all lamps in position, or both poles of the installation otherwise electrically connected together, a direct current pressure of not less than twice the working pressure, provided it need not exceed 500 volts for medium voltage, circuits, where the supply is derived from a three wire D.C. or a polyphase A.C.system the neutral pole of which is connected to earth either directly or through added resistance, the working pressure shall be deemed to that which is maintained between the phase conductor and the neutral.

3.2.2 The insulation resistance shall also be measured between all the conductors connected to one pole, or phase conductor of the supply, and all the conductors conned to the neutral, or to the other pole or phase conductors of the supply with all the lamps in position, and switches in off position, and its value shall be not less than that specified in sub clause 3.1.3.

3.2.3 The insulation resistance in mega ohms measured as above shall not less than 12.5 mega ohms for the wiring with PVC insulated cable subject to a minimum of 1 megaohm.

3.2.4 Where a whole installation is being tested, a lower value than that given by the formula, subject to a minimum of 1 megaohm, is acceptable.

3.2.5 A preliminary and similar test may be made before the lamps etc. are installed, and in this event the insulation resistance to earth should not be less than 25 megaohms for the wiring with PVC insulated cables, subject to a minimum of 2 megaohms.

3.2.6 The term outlet includes every point along with every switch except that a switch combined with a socket outlet, appliance or lighting fitting is regarded as one outlet.

3.2.7 Control rheostats, heating and power appliances and electric signs may, if required, be disconnected from the circuit during the test, but in that event the insulation resistance between the case or frame work, and all live parts of each rheostat, appliance and sign shall be not less than that specified in the relevant Indian Standard Specifications, or where there is no such Specification, shall be not less than one megaohm.

3.3 POLARITY TEST OF SWITCH

3.3.1 In a two wire installation a test shall be made to verify that all the switches in every circuit have been fitted in the same conduits throughout, and such conductor shall be labeled or marked for connection to the phase conductor or to the non-earthed conductors of the supply.

3.3.2 In a three wire or a four wire installation, a test shall be made to verify that every non linked single pole switch is fitted in a conductor which is labeled, or marked for connection to one of the phase conductors of the supply.

3.3.3 The installation shall be connected to the supply for testing the terminals of all switches shall be tested by a test lamp, one lead of which is connected to the earth. Glowing of test lamp to its full brilliance, when the switch is in 'ON' position irrespective of appliance in position or not, shall indicate that the switch is connected to the right polarity.

3.4 TESTING OF EARTH CONTINUITY PATH

The earth continuity conductor, including metal conduits and metallic envelopes of cables in all cases, shall be tested for electric continuity. The electrical resistance of the same along with the earthing lead, but excluding any added resistance, or earth leakage circuit breaker, measured from the connection with the earth electrode to any point in the earth continuity conductor in the completed installation shall not exceed one ohm.

3.5 MEASUREMENT OF EARTH ELECTRODE RESISTANCE

3.5.1 Two auxilliary earth electrode, besides the test electrode, are placed at suitable distance from the test electrode (see figure). A measured current is passed between the electrode 'A' to be tested and an auxilliary current electrode 'C' and the potential difference

between the electrode 'A' and auxilliary potential B' is measured. The resistance of the test electrode 'A' is then given by;

$$R = \frac{V}{I}$$

Where,

- R = Resistance of the test electrode in ohms.
- V = Reading of the voltmeter in volts.
- I = Reading of the ammeter in amps

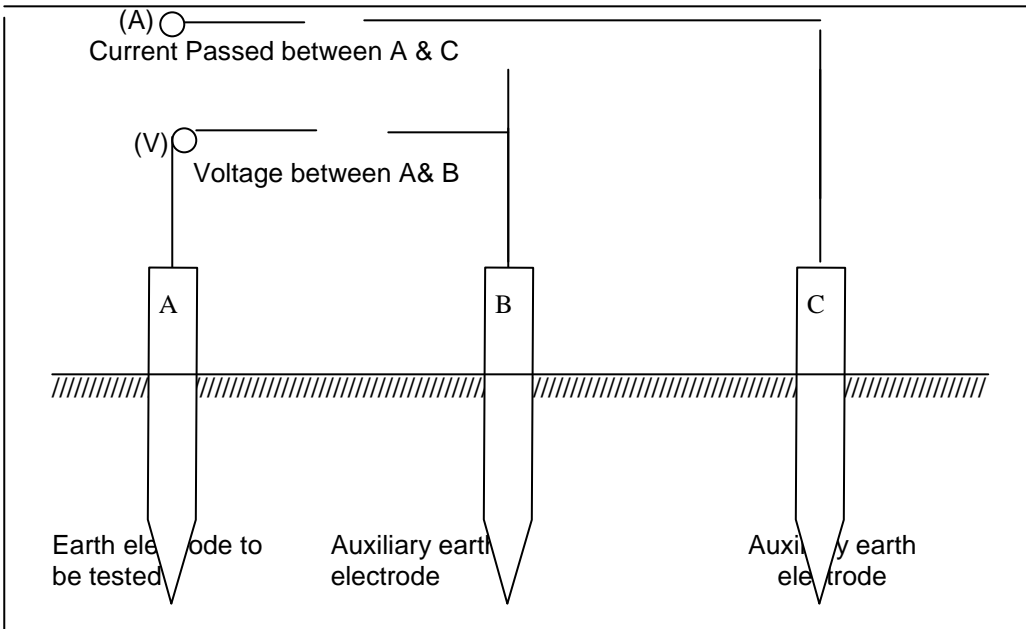

3.5.2

(i) Stray currents flowing in the soil may produce serious errors in the measurement of earth resistance. To eliminate this, hand driven generator is used.

(ii) If the frequency of the supply of hand driven generator coincides with the frequency of stray current, there will be wandering of instrument pointer. An increase or decrease of generator speed will cause this to disappear.

3.5.3 At the time of test, the test electrode shall be separated from the earthing system.



## NIT NO. **BHO202004031**

- 3.5.4 The auxillary electrodes shall be of 13mm diameter mild steel rod driven upto 1m into the ground.
- 3.5.5 All the three electrodes shall be so placed that they are independent of the resistance area of each other. If the test electrode is in the form of a rod, pipe or plate, the auxillary current electrode 'C' shall be placed at least 30m away from it, and the auxillary potential electrode 'B' shall be placed mid way between them.
- 3.5.6 Unless three consecutive readings of test electrode resistance agree, the test shall be repeated by increasing the distance between electrodes A and C upto 50m and each time placing the electrode B midway between them.
- 3.5.7 On these principles, 'Megger Earth Tester' containing a direct reading ohm-meter, a hand driven generator and auxillary electrodes are manufactured for direct reading of earth resistance of electrodes.

### 3.6 TEST CERTIFICATE

On completion of an electrical installation (or an extension to an installation) a certificate shall be furnished by the contractor, countersigned by the certified supervisor under whose direct supervision the installation was carried out. This certificate shall be in the prescribed form as given in Appendix 'A' in addition to the test certificate required by the Local Electric Supply Authorities.

## **CHAPTER-IV**

### **MCB TYPE DISTRIBUTION BOARDS**

- 4.1 (i) MCBDB's may be of single phase, 3 phase (horizontal type) suitable for feeding single phase loads, or 3 phase (vertical type) suitable for feeding single phase as well as 3 phase loads as specified. These shall be complete with accessories, but without MCBs which shall be specified as a separate item in the tender documents.
- (ii) The current ratings and the number of ways shall be as specified. Blanking plates shall be provided to close unused ways.
- (iii) DB with integral incomer
- Where it is proposed to install the controlling MCCB/ELCB/MCB, the total number of outgoing MCBs will be reduced by one or two numbers corresponding to SP or SP&N at the incoming, since the total number of ways are fixed in MCBDBs. Bus bars in such units shall also be correspondingly shorter. The inter connections shall be done between the incomer and outgoing as part of the DB in the works.
- (iv) MCBDBs shall be of surface/flush mounting pattern according to the requirement of their location and shall be suitable to accomodate MCB's and ELCB at incoming as well as outgoing in single pole or multipole configuration as required.
- (v) MCBDB's shall be dust and vermin proof conforming to IP 42 and shall be fabricated out of CRCA sheet steel. 1.2 mm thick with stove enamelled paint finish.
- (vi) MCBDB's shall have removable type end plates with knock outs at the bottom and top.
- (vii) Only the knobs of the MCBs shall protrude out of the front covers through openings neatly machine made for the purpose.
- (viii) The bus bars used shall be solid electrolytic copper of appropriate sections.
- (ix) DIN bar(s) shall be provided for mounting the MCBs.

### 4.2 PRE-WIRED MCB DISTRIBUTION BOARDS

- (i) Prewired MCBDBs shall be provided only where specified.
- (ii) The complete board shall be factory fabricated and shall be duly prewired in the works, dy for installation at site.
- (iii) The board shall be of wall mounted cubical type construction, fabricated out of 1.2 mm thick sheet steel with stove enamelled paint finish.
- (iv) The board shall also be provided with a loose wire box ( if mentioned in the scope of work ) as a compartment for the complete width and, depth of the board and of minimum height of 125 mm in case of TPN DB's and 100 mm in case of SPN BD's.
- (v) The board shall be provided with a hinged cover of 1.6mm thick sheet steel in the front. Only the knobs of the MCBs shall protrude out of the front covers through openings neatly machine made for the purpose.

## NIT NO. **BHO202004031**

(vi) Knock out holes at the bottom and detachable plate with knock out holes at the top of the board shall be provided.

(vii) The board shall be complete with the following accessories.

- (a) 200A copper bus bar(s)
- (b) Neutral link
- (c) Common earth bar
- (d) Din bar for mounting MCBs
- (e) Elemex type terminal connectors suitable for incoming and outgoing cables.
- (f) A set of indication lamps with HRC cartridge fuses for each phase of the incoming supply.
- (g) Earthing stud(s).

(viii) The board shall be fully prewired with single core PVC insulated copper conductors/insulated solid copper links and terminated on to extended type terminal connectors, suitable for connections to the sizes of the respective conductors.

(ix) All incoming and outgoing wiring to the prewired MCBDB's shall be terminated only in the Elemex type extended terminal connectors to be provided within the DB. The terminal connectors shall therefore be so provided as to facilitate easy cable connections and subsequent maintenance.

(x) A common copper earth bar shall be provided within the loose wire box. The common neutral bar as well as the terminal connectors shall however be provided within the main compartment just below the loose wire box.

### 4.3 MINIATURE CIRCUIT BREAKERS (MCB's)

- (i) 'Light' series 10 KA Breaking Capacity shall be used only for normal 'lighting' circuits.
- (ii) 'Power' series 10 KA Breaking Capacity MCB's shall be invariably used for motor loads helogen lamp fittings, sodium/mercury discharge lamps and all 'power' circuits.
- (iii) Ratings (Amps as well as KA), number of poles, type as MCB or isolator, etc. shall be as specified in the tender documents.

## **CHAPTER : V MEDIUM VOLTAGE CABLING**

### 5.0 Scope

5.1 The scope of work shall cover supply, laying, connecting, testing and commissioning of low and medium voltage power and control cabling.

### 5.2 Standards

5.2.1 The following standards and rules shall be applicable:

- 1) IS:1554 PVC insulated electric cables (heavy duty)
- 2) IS:1753 Alluminium conductors for insulated cables
- 3) IS:961 Recommended current ratings for cables.

4) Indian electricity act and rules. All codes and standards mean the latest. Where not specified otherwise the installation shall generally follow the Indian Standard Codes of Practice or the British Standard Codes of Practice where Indian Standards are not available.

### 5.3 Cables

5.3.1 All cables shall be 1100 volt grade PVC insulated, sheathed with or without steel armouring as specified and with an outer PVC protective sheath. Cables shall have high conductivity stranded alluminium or copper conductors and cores colour coded to the Indian Standards.

5.3.2 All cables shall be new without any kinds or visible damage. The manufacturers name, insulating material, conductor size and voltage class shall be marked on the surface of the cable at every 600mm centres.

### 5.4 Installation

5.4.1 Cables shall be laid in the routes marked in the drawings. Where the route is not marked, the contractor shall mark it out on the drawings and also on the site and obtain the approval of the Architect/Consultant before laying the cable. Procurement of cables shall be on the basis of actual site measurements and the quantities shown in the schedule of work shall be regards as a guide only.

5.4.2 Cables, running indoors shall be laid on walls, ceiling, inside shafts or trenches. Single cables laid shall be fixed directly to walls or ceiling and supported at not more than 500mm. Where number of cables are

## NIT NO. BHO202004031

run, necessary perforated cable trays shall be provided wherever shown. Perforated trays shall be mild steel or aluminium as specified in the schedule of work and supported on mild steel frame work as shown on drawings or as approved. Cables laid in built up trenches shall be on steel supports. Plastic identification tags shall be provided at every 30m.

5.4.3 Cables shall be bent to a radius not less than 12 (twelve) times the overall diameter of the cable or in accordance with the manufacturer's recommendations whichever is higher.

5.4.4 In the case of cables buried directly in ground, the cable route shall be parallel or perpendicular to roadways, walls etc. cables shall be laid on an excavated, graded trench, over a sand or soft earth cushion to provide protection against abrasion. Cables shall be protected with brick or cement tiles as shown on drawings. Width of excavated trenches shall be as per drawings. Backfill over buried cables shall be with a minimum earth cover of 600mm. The cables shall be provided with cables markers at every 35 meters and at all loop points.

5.4.5 The general arrangement of cable laying is shown on drawings. All cables shall be full runs from panel to panel without any joints or splices. Cables shall be identified at end terminations indicating the feeder number and the Panel/Distribution board from where it is being laid. All cable terminations for conductors upto 4 sqmm may be insertion type and all higher sizes shall have tinned copper compression lugs. Cable terminations shall have necessary brass glands. The end terminations shall be insulated with a minimum of six half lapped layers of P.V.C. tapes. Cable armouring shall be earthed at both ends.

### 5.5 Testing

5.5.1 MV cables shall be tested upon installation with a 500V Meggar and the following readings established

1) Continuity on all phases

2) Insulation Resistance

(a) between conductors

(b) all conductors and ground All test readings shall be recorded and shall form part of the completion documentation.

## SECTION : VI

### EARTHING

#### 6.0 Scope

6.1 The scope of work shall cover earthing stations, laying aluminium/copper earth strips and connecting the power panels, DBs and switch boards.

#### 6.2 Standards

6.2.1 The following standards and rules shall be applicable:

1) IS:3043-1966 Code of Practice for earthing.

2) Indian Electricity Act and Rules.

6.2.2 All codes and standards mean the latest. Where not specified otherwise the installation shall generally follow the Indian Standard Code of Practice or the British Standard Codes of Practice in the absence of Indian Standards.

#### 6.3 Plate Earthing Station

6.3.1 The substation earthing shall be with copper plate earthing station unless otherwise specified.

6.3.2 The earthing station shall be as shown on the drawing. The earth resistance shall be maintained with a suitable soil treatment.

6.3.3 The resistance of each earth station should not exceed 2 ohms.

6.3.4 The earth lead shall be connected to the earth plate through copper/brass bolts.

#### 6.4 Pipe Earthing Station

6.4.1 The earth station shall be as shown on the drawing and shall be used for equipment earth grid. The earth electrode shall be 2.5 meter long 40mm dia galvanized steel pipe. The earth resistance shall be maintained with a suitable soil treatment.

6.4.2 The resistance of each earth station should not exceed 5 ohms.

6.4.3 The earth lead shall be fixed to the pipe with a clamp and safety set screws. The clamps shall be permanently accessible.

**NIT NO. BHO202004031**

**6.5 Earth leads and connections**

6.5.1 Earth lead shall be bare copper or aluminium or galvanised steel as specified with sizes shown on drawings. Copper leads shall have a phosphor content of not over 0.15 percent. Aluminium and galvanised steel buried in ground shall be protected with bitumen and hessian wrap or polythene faced hessian and bitumen coating. At road crossings necessary hume pipes shall be laid. Earth lead run on surface of wall or ceiling shall be fixed on saddles or wall so that the strip is atleast 8mm away from the wall surface.

6.5.2 All earth strip shall be jointed as follows:

Copper Copper rivetting with 80mm fish plate and brazing  
Alluminium Riveting with 2 Nos. 100mm long bimetal fish plates using copper rivets  
Galvanised Steel Lap welding with 50mm minimum lap

6.5.3 All strips shall be run on walls/beams with 6mm thick galvanised steel earth saddles at 500mm centre to centre.

**6.6 Equipment Earthing**

6.6.1 All apparatus and equipment transmitting or utilising power shall be earthed in the following manner. Copper earth wires shall be used where copper wires are specified. Aluminium wires may be used where aluminium phase wires are specified unless otherwise indicated in the schedule of work.

**6.6.2 Power transmission apparatus**

Metallic conduit shall not be accepted as an earth continuity conductor. A separate insulated/bare earth continuity conductor of size 50% of the phase conductor subject to the minimum and maximum shall be provided.

	Copper	Alluminium	Galvanised Steel
Minimum (sqmm)	2.5	4.0	6
Maximum (sqmm)	65	100	200

The earth continuity conductor may be drawn inside the conduit in which case, it should be insulated.

6.6.3 Non-metallic conduit shall have an insulated earth continuity conductor of the same size as for metallic conduit. All metal junction and switch boxes shall have an inside earth stud to which the earth conductor shall be connected. The earth conductor shall be distinctly colored (green) for easy identification.

6.6.4 Armoured cables shall be earthed by 2 distinct earth connections to the armouring at both the ends and the size of connection being as for the metallic conduit.

6.6.5 In the case of unarmoured cable, an earth continuity conductor shall either be run outside along the cable or should form a separate insulated core of the cable.

6.6.6 3 Ph. power panels and distribution boards shall have 2 distinct earth connections of the size correlated to the incoming cable size. In case of 1 Ph. DB's a single earth connection is adequate. Similarly for 3 Ph and 1 Ph isolating switches there shall be 2 and 1 earth connections respectively, sizes being correlated to the incoming cable.

**6.6.7 Utilising Equipment**

3 Ph. motors and other 3 Ph apparatus shall have 2 distinct earth connections of size equal to 50% of the connecting cable subject to the following:

	Copper	Alluminium	Galvanised Steel
Minimum (sqmm)	6.5	10	20
Maximum (sqmm)	65	100	200

6.6.8 For 1 Ph motors and 1 Ph apparatus, the single earth connections shall be provided of the above size. For all light fittings and fans a single earth connection with 2.5 sqmm copper or equivalent size shall be provided.

6.6.9 All street light poles shall have an earth stud and shall be connected to the cable armouring using 6.5 sqmm copper or equivalent unless shown otherwise. For street lighting poles planted in ground, 2.4 meter long 10 SWG bare copper wire shall be coiled and buried with every fourth pole in addition to connection to cable armouring.

6.6.10 An equipment earthing grid is established as shown on the drawings. All earth connections to all panels, DBs and equipment shall be connected to the nearest point of the earthing grid.

6.7 Testing

-----

6.7.1. The following earth resistance values shall be measured with an approved earth meggar and recorded.

- 1) Each earthing station
- 2) Earthing system as a whole
- 3) Earth continuity conductors

**CHAPTER : VII**  
**MV SWITCHGEAR**

-----

7.0 Scope

-----

7.1 The scope of work shall cover the supply, installation, testing and commissioning of all power panels, incorporating, switch fuses, bus bars, and contactor interconnections, earthing etc. meeting the requirements shown in equipment schedule and the drawings.

7.2 Standards

7.2.1 The following standards and rules shall be applicable:

- 1) IS:2516-1972 Specification for AC circuit breakers.
- 2) IS:4047-1977 Specification for Heavy duty air breaker switch gear and fuses for voltage not exceeding 1000 V.
- 3) IS:1818-1972 Specification for AC isolator and earthing switches.
- 4) IS:3072-1975 Code of Practice for installation and maintenance of switch gear.
- 5) IS:3106-1966 Code of Practice for selection, installation and maintenance of fuses (Voltage not exceeding 650 V).
- 6) IS:4237-1967 General requirements for switch gear and control gear for voltage not exceeding 1000 V.
- 7) IS:2607-1976 Air break isolators for Voltages not exceeding 1000 V.
- 8) IS:8623-1977 Specification for factory built assemblies of switch gear and control gear for voltage upto and including 1000 V AC and 1200 V DC.
- 9) Marking and arrangement of switch gear bus bars main connections and auxillary wiring.
- 10) Indian Electricity Act and Rules.

All codes and standards mean the latest. Where not specified otherwise the installation shall generally follow the Indian Standard Codes of Practice or the relevant British Standard Codes of Practice in the absence of corresponding Indian Standards.

7.3 Circuit Breakers

7.3.1 Circuit breakers shall be air break horizontal draw out type fully interlocked and meeting the requirements of IS:2516 or BS:3659. Breakers shall be rated for a medium voltage of 600 V and rated full load amperes as indicated on drawings. Breaker shall be capable of making and breaking system short circuits specified.

7.3.2 Breakers shall be unless specified otherwise manually operated, complete with front-of-the-panel operating handle, isolating plug with safety shutters, mechanical ON/OFF indicator, silver plated arcing and main contacts, are chutes, trip free operating. Breakers shall be capable of being racked out into 'Testing', 'Isolator' and 'Maintenance' positions and kept locked in any position. Breakers for remote operation shall be motor operated spring charged.

7.4 MCCB's

## NIT NO. **BHO202004031**

7.4.1 Moulded case circuit breakers shall be standard products of established manufacturers and shall conform to BS:3871. Breakers shall be rated for system short circuit levels and if unavoidable, backed up by HRC fuses. Breakers shall incorporate thermal and magnetic trips unless shown otherwise in the drawings.

### 7.5 Switch Fuse Units & Disconnects

7.5.1 Switch fuse units shall have quick make, quick break silver plated preferably double break contacts with operating mechanism suitable for rotary operation in the case of cubicle mounting.

All switches shall be rated according to the equipment schedule or drawings and shall withstand the system prospective fault current let through. Cam operated rotary switches with adequate terminal adaptors upto 25A are acceptable but for all higher rating switch fuse units shall be heavy duty type conforming to IS:4047.

7.5.2 Fuses shall be HRC cartridge type conforming to IS:2208 with a breaking capacity corresponding to system fault level. Fuses shall be link type with visible indication. Screw type diazed fuses are not acceptable for any ratings.

7.5.3 All disconnects shall consist of switch units quick make, quick break type with silver plated contacts. The switches shall preferably have double breaks. The switches shall preferably have sheet steel enclosures, which in turn is mounted on suitable angle iron frame work. In wet locations switches shall have cast iron enclosures. Disconnects shall have a minimum breaking capacity of 5KV at 415 Volts.

### 7.6 Instrument Transformers, Meters & Relays

7.6.1 Ammeters and Voltmeters shall have moving iron spring controlled dead beat elements in square-bezel flush type cases 96mm in size and suitable for switch board mounting. Meters shall conform to BS:89 and have grade 'A' accuracy. Scale ranges shall meet with the requirements or as indicated on the drawing or in the Schedule of quantities.

7.6.2 Electronic energy meters shall be two element switch board mounting type suitable for unbalanced loads. Meters should incorporate a KVA demand meter with an integration time of 30 minutes. In case of two incoming feeders, a summing CT shall be provided with the meter. Meters shall conform to BS:37. The energy meters for DG Set and Transformer shall be calibrated and got certified by the respective Electricity Authority.

### 7.7 Cubicle Boards

7.7.1 All boards shall be combination of 14 and 16 SWG sheet steel free standing, extensible, totally enclosed, dust tight, vermin proof cubicle, flush dead front and modular construction suitable for 3 phase 415V 4 wire 50 Hertz system. All boards shall be accessible from the front for the maintenance of switch fuses, bus bars, cable terminations, meters etc. Cables shall be capable of entering the board both from top as well as bottom. All panels shall be machine pressed with punched openings for meters etc. All sheet steel shall be rust inhibited through a process of degreasing, acid picking, phosphating etc. The panels shall be finished with two coats of synthetic enamel of approved colour over one coat of red oxide primer. Engraved plastic labels shall be provided indicating the feeder details, and capacity and danger signs.

7.7.2 The boards shall accommodate air insulated bus bars, air circuit breakers, switch fuse units with HRC fuses, starters, necessary meters, relays contracts etc. as required and arranged in suitable tiers. All breakers and switch fuses shall be suitably derated taking into account specified ambient temperature and rulling temperature inside the cubicle.

7.7.3 The switch board shall be fully compartmentalised in vertical tiers housing the feeder switches in totally enclosed independent compartments. Each compartment shall be self sufficient with switch unit, fuses, contractors, relays, indicating lamps and an inter locked door with facility for padlocking. Each feeder must terminate in an independent labelled terminal block. Strips type terminal block accommodating several feeders together is not acceptable. Pressure clamp type terminals suitable for aluminium wires may be used upto switches of 25A and cable lugs for higher ratings. All terminations shall be shrouded in an approved manner. The entire enclosure shall meet with IS:2147/1962. Feeder connections shall be cut of solid insulated copper/aluminium wires or strips with bimetallic clamps wherever required.

**NIT NO. BHO202004031**

Internal wiring, bus bar markings etc. shall conform to IS:375/1963. Internal wiring shall have terminal ferrules. Main switch should be at an easily accessible height and the highest switch operating handle should not be over 1.75m from floor level. Cable glands need not form part of the switch board as the cost of glands will form part of the cable termination.

**7.8 Bus Bars**

7.8.1 Bus bars shall be three phase and neutral and of copper or alluminium or alluminium alloy as specified and shown on drawings and rated for a temperature specified, based on insulated conductor rating (IS:8084-1976). Neutral bars may be of one half the size of the phase bars.

The main horizontal bus bars shall be of uniform cross section and rated in accord with the incoming switch. e vertical bus bars for the feeder columns may be rated at 75% of aggregate feeder capacity and shall be uniform in size. Bus bars and interconnections shall be taped with PVC colour coded tape to prevent bar-to-bar accidental shorts. Each bus bar shall be directly and easily accessible on removal of the front cover. Bus bars shall be totally enclosed, shrouded and supported on non-hygroscopic insulator blocks to withstand thermal and dynamic overloads during system short circuits. An earth bus of size 50% of the phase subject to the following maximum and minimum shall be provided. Individual switch components shall be connected with the earth bus through copper or alluminium or galvanized steel strip size as shown. All wire connections to bars shall be through lugs, bolts and nuts and spring washers.

	Copper	Alluminium	Galvanized Steel
Minimum	6.5 sqmm	10 sqmm	16 sqmm
Maximum	65 sqmm	120 sqmm	200 sqmm

The minimum size of earth bar in a board shall however be 15 x 3 Cu or 25 x 3 Al. or equivalent.

**7.9 Isolators**

7.9.1 Isolators shall be fixed on wall on self supported angle iron frame work as required and mounted as near to the motor as possible. Where several motors are installed, isolators if required shall be provided at a central location on a common frame work.

7.9.2 Painting, earthing and lables shall be provided as generally indicating for MV switch gear.

**7.10 Earthing**

7.10.1 All switch panels shall be provided with an earth bar as specified.

7.10.2 Earthing of the switch boards shall be through the equipment earthing system provided in the building with two earth connection as shown.

**7.11 Installation**

7.11.1 All panels shall be supported on MS channel incorporated in the panel during the fabrication. all such supports shall be prime coated with two finish coats after completion of the work all panels shall be touched up for damaged painting.

7.11.2 All panels shall be meggared phase to phase and phase to neutral using a 1000V meggar with all outgoing feeders in closed position. The meggar value should not be less than 2.5 megohms between phases and 1.5 megohms between phases and neutral.

7.11.3 Fabrication drawings of all panels shall be approved by the Consulting Engineers before fabrication.

**7.12 Testing & Inspections**

7.12.1 All switch boards shall be factory inspected before finishing and dispatch.

7.12.2 Certificate for all routine and type tests for circuit breakers in accordance with the IS:2516- 1963 shall be finished. In addition, all panels shall be meggared phase to phase and phase to neutral, using a 1000V meggar with all switch gear in closed position. The meggar value should not be less than 2.5 megohms between phases and 1.5 megohms between phase and neutral.

**DECLARATION**

I/We have inspected the site JAWAHAR CHOWK BRANCH of State Bank of India and I/We have made me/ us fully acquainted with the local conditions in and around the sites of works and Lay out drawings of works, drawings of each items etc. complete.

I/We hereby declare that I/ We have carefully gone through the conditions laid down in the Notice Inviting Tender, General notes, General Conditions of Contract, Special conditions, Schedule of approximate quantities and rates , Form of Agreement, General Specification, Approved manufacturers/ natural source of materials (i.e. all parts of Technical bid), Technical Specifications of schedule of quantities (i.e. all parts of Price bid), and clearly understood all the same and on the basis of the same I/ We have quoted our rates in the Schedule of Quantities/BOQ attached with the tender documents.

We accept all the terms and conditions of tender documents. We will abide by the technical specification mentioned in the tender. We here by undertake to use only specified material/ make as per the tender schedule.

I/ We hereby declare that, in particular during execution of all works at site; it will be my/ our sole responsibility to strictly adhere to/ meticulously follow the General Specification, Approved manufacturers/ natural source of materials, Technical Specifications of schedule of quantities, all drawings of layout and items.

For any type of deviation (to any of above or subsequent instructions), it will be my/ our responsibility to obtain the written instruction of the Engineer-in-charge for the same failing which it shall be deemed that I have carried out any such deviations at my own and I shall be duty bound to replace the all deviated material/ works from the site at my/ our cost as well as I shall be liable to penalized by the employer as deemed fit and for all such loses made thereof, I/ we shall not have any right to arbitrate in any manner.

I/ We hereby declare that I/ We shall obtain necessary drawings of items from employer in time and also shall uniformly maintain such progress as may be directed by the employer to ensure completion of same within the target date/ time as mentioned in the tender document.

Date:

Signature and seal of Contractor/ Tenderer

**Witness:**

- 1.
- 2.

**NOTE**

**ANY CLARIFCATIONS SOUGHT AFTER OPENING OF THE TENDERS WILL NOT BE ENTERTAINED AT ANY COST.**



Annexure-A

The steps involved in making the payment through SB Collect are as under:-

1. The Vendor needs to use SBI internet banking site <http://www.onlinesbi.com/>.
2. Select “**SB Collect**” from Top Menu, that will lead to the next page:
3. “**Proceed**” will lead to the next page”
4. Select “**All India**” in State of Corporate/Institution” & select “**Commercial Services**” in “Type of Corporate/Institution”.
5. “**Go**” will lead to the next page”
6. Select “**SBI Infra Management Solutions**” in Commercial Services Name and “Submit”
7. Select “**Tender Application Fee**” in “Payment Category” and enter the “**Tender ID**” exactly as we preloaded with characters in Uppercase only in place of Circle Codes.
8. The next page will be ready with few of the Preloaded Tender Details:
9. The Vender will have to fill up the fields properly and upon making the payment a receipt will be generated with a Reference No.

***NOTE: Any type of vender, whether dealing with SBI or other bank can use the SB Collect facility.***

**Even a contractor not dealing with any bank can use this portal and generate challan and deposit by cash in any SBI branch. The bank charges for cash deposit will be also borne by the vender himself.**